

UCL-X product information sheet

Product Specifications

Fits most: 42" - 70" flat panels

Supports up to: 200 lbs (90.7 kg)

Tilt: -5° to +15°

Mounting profile: 4.3" (110mm)*

Maximum extension: 26.4" (672mm)*

Universal & VESA compliant:

100x100 to 600x800

Mounting: Double-stud

Warranty: 5 years

Color: Black and Platinum

*Adapter adds 1.4" (36mm)

Product Benefits

- Tilt, pan and swivel for maximum viewing flexibility
- Die-cast aluminum construction for maximum support in a lightweight mount
- Double-arm I-beam design for added strength
- Includes universal adapter for greater panel compatibility
- Innovative 4-link tilt mechanism for smooth, effortless movement
- Double-capacity cable management system guides wires
- Rack and pinion mechanism for easy self-centering



- Built-in screen leveling
- Lift n' Lock™ allows you to easily attach your flat panel to the mount
- Sliding lateral on-wall adjustment
- Wall plate equipped with dual gang J-Box cutouts
- Locking system secures panel to mount
- Installation template for simple and accurate mounting
- Includes complete hardware kit



A double-capacity cable management system is seamlessly integrated into the UCL-X, allowing for twice as many cables to be neatly tucked away within the arm's housing



2005 CEDIA Manufacturers' Excellence Award

Series

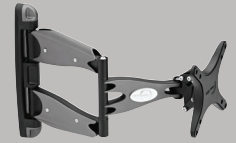

CL-S



CL-M



UCL-L



UCL-X



OmniMount, an innovator of A/V mounts and furniture for more than a quarter century, is the choice of professional installers and the brand most recommended by flat panel manufacturers. The popular Architectural Series is a full line of full motion mounts with innovation, durability and maximum functionality built right in. The UCL-X is ideal for anyone requiring an extra large universal heavy-duty full motion flat panel mount with advanced features.



UCL-X technical data sheet



OmniMount, an innovator of A/V mounts and furniture for more than a quarter century, is the choice of professional installers and the brand most recommended by flat panel manufacturers. The Architectural Series is our flagship full motion series with innovation, durability and maximum functionality built right in. The UCL-X is ideal for those customers or jobs requiring an extra large universal heavy duty full motion mount with advanced features.

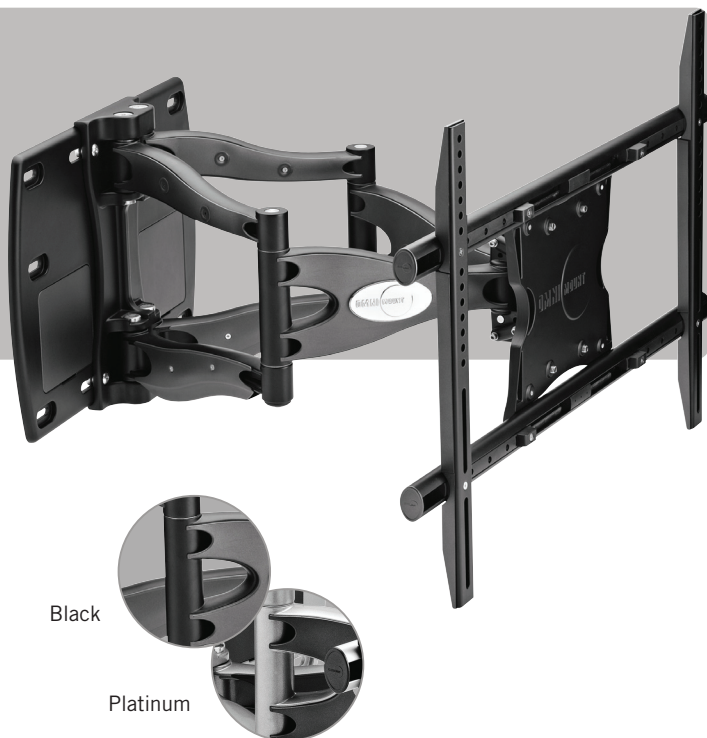

Product Specifications

Fits most: 42" - 70" flat panels

Supports up to: 200 lbs (90.7 kg)

Tilt: -5° to +15°

Mounting profile: 4.3" (110mm)*

Maximum extension: 26.4" (672mm)*

Universal & VESA compliant:

100x100 to 600x800

Mounting: Double-stud

Warranty: 5 years

Color: Black and Platinum

*Adapter adds 1.4" (36mm)

Product Benefits

- Tilt, pan and swivel for maximum viewing flexibility
- Die-cast aluminum construction for maximum support in a lightweight mount
- Double-arm I-beam design for added strength
- Includes universal adapter for greater panel compatibility
- Innovative 4-link tilt mechanism for smooth, effortless movement
- Double-capacity cable management system guides wires
- Rack and pinion mechanism for easy self-centering
- Built-in screen leveling

- Lift n' Lock™ allows you to easily attach your flat panel to the mount
- Sliding lateral on-wall adjustment
- Wall plate equipped with dual gang J-Box cutouts
- Locking system secures panel to mount
- Installation template for simple and accurate mounting
- Includes complete hardware kit

	Color	Stock Code	Packaging UPC
Americas	Platinum	1002474-1	728901014956
International	Platinum	1002755-1	728901016622
Americas	Black	1003077-1	728901016950
International	Black	1002984-1	728901017339

	Dimensions WxDxH Inches (mm)	Wt lbs (kg)	Qty
Box	22.2 x 34.7 x 6.7 (565x880x170)	47.4 (21.5)	NA
MC	NA	NA	NA

Box Contents	Qty
Wall plate	1
Cantilever arm	1
Universal adapter	1
VESA plate	1
Cable management cover	8

Box Contents	Qty
Complete mount installation hardware kit	1
Complete panel attachment hardware kit	1
Installation template	1
Instruction manual	1
Flat panel compatibility chart	1

UCL-X line drawing

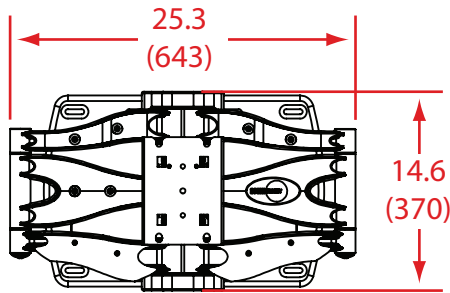

FRONT VIEW

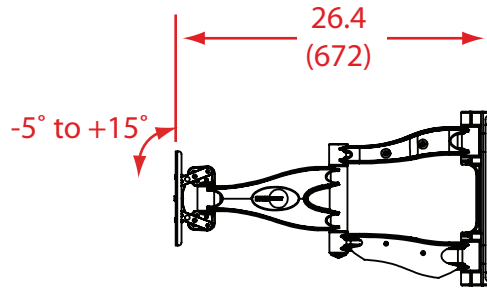

MAXIMUM EXTENSION

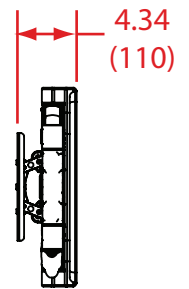

MOUNTING PROFILE

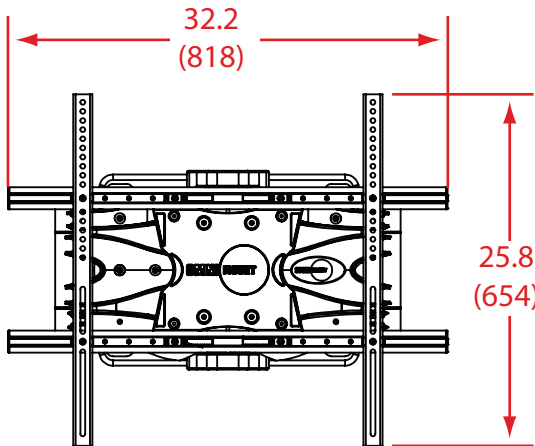

FRONT VIEW WITH ADAPTERS

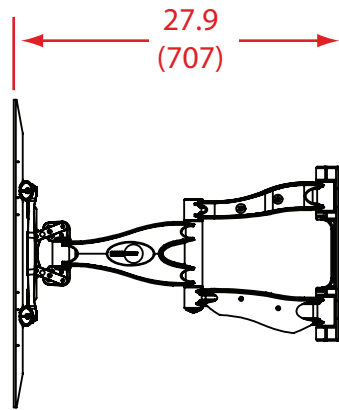

MAXIMUM EXTENSION WITH ADAPTERS

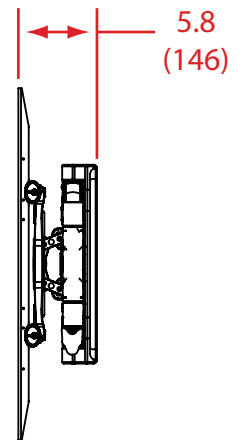

MOUNTING PROFILE WITH ADAPTERS

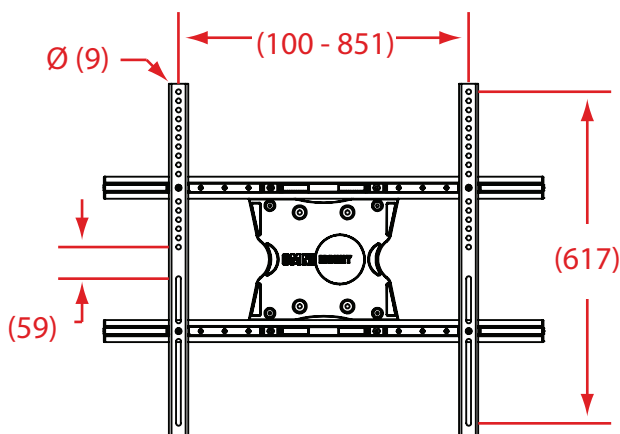

PANEL ATTACHMENT - VESA COMPATIBILITY (mm)

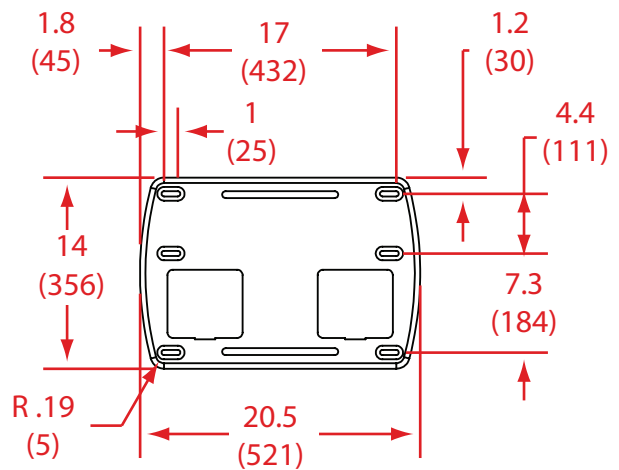

WALL MOUNTING

inches (mm)