

# SONY®

# Cyber-shot

**Digital Still Camera**

## **Cyber-shot Handbook**

**DSC-T500**

Before operating the unit, please read this Handbook thoroughly together with the “*Instruction Manual*” and the “*Cyber-shot Step-up Guide*”, and retain them for future reference.

▼CLICK!



Table of contents



Basic Operations



Using the shooting functions



Using the viewing functions



Customizing the settings



Viewing images on a TV



Using your computer



Printing still images



Troubleshooting



Others



Index

# Notes on using the camera

## Notes on the types of “Memory Stick” that you can use (not supplied)



### “Memory Stick Duo”:

You can use a “Memory Stick Duo” with the camera.



### “Memory Stick”:

You cannot use a “Memory Stick” with the camera.

## Other memory cards cannot be used.

For details on “Memory Stick Duo”, see page 127.

## When using a “Memory Stick Duo” with “Memory Stick” compatible equipment

You can use the “Memory Stick Duo” by inserting it into the Memory Stick Duo Adaptor (not supplied).



Memory Stick Duo Adaptor

## Notes on the battery pack

- Charge the battery pack (supplied) before using the camera for the first time.
- You can charge the battery pack even if it is not completely discharged. In addition, even if the battery pack is not fully charged, you can use the partially charged capacity of the battery pack as is.
- If you do not intend to use the battery pack for a long time, use up the existing charge and remove it from the camera, then store it in a cool, dry place. This is to maintain the battery pack functions.
- For details on the usable battery pack, see page 129.

## Carl Zeiss lens

The camera is equipped with a Carl Zeiss lens which is capable of reproducing sharp images with excellent contrast.

The lens for the camera has been produced under a quality assurance system certified by Carl Zeiss in accordance with the quality standards of Carl Zeiss in Germany.

## Notes on the LCD screen and lens

- The LCD screen is manufactured using extremely high-precision technology so over 99.99% of the pixels are operational for effective use. However, some tiny black and/or bright dots (white, red, blue or green) may appear on the LCD screen. These dots are a normal result of the manufacturing process and do not affect the recording.

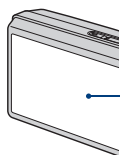

Black, white, red, blue or green dots

- If water droplets or other liquids splash on the LCD screen and make it wet, immediately wipe off the screen with a soft cloth. Leaving liquids on the LCD screen surface can harm the quality and cause a malfunction.
- Exposing the LCD screen or the lens to direct sunlight for long periods may cause malfunctions. Be careful when placing the camera near a window or outdoors.
- Do not press against the LCD screen. The screen may be discolored and that may cause a malfunction.
- Images may trail across on the LCD screen in a cold location. This is not a malfunction.
- Be careful not to bump the lens, and be careful not to apply force to it.

### **Note when playing movies on other devices**

This camera utilizes MPEG-4 AVC/H.264 Main Profile to record movies. Therefore, movies recorded using this camera cannot be played on devices that do not support MPEG-4 AVC/H.264.

### **The images used in this Handbook**

The images used as examples in this Handbook are reproduced images, and are not actual images shot using this camera.

# Table of contents

Notes on using the camera .....	2
Basic techniques for better images .....	8
Focus – Focusing on a subject successfully .....	8
Exposure – Adjusting the light intensity .....	10
Color – On the effects of lighting .....	11
Quality – On “image quality” and “image size” .....	12
Flash – On using the flash .....	14
Identifying parts .....	15
Indicators on the screen .....	17
Operating the touch panel .....	21
Changing the screen display .....	22
Using the internal memory .....	24

## Basic Operations











Shooting still images .....	25
Shooting movies .....	29
Viewing images .....	31
Deleting images .....	35
Learning the various functions – HOME/Menu .....	36
Menu items .....	39

## Using the shooting functions











Switching the shooting mode .....	41
Shooting images according to the scene mode .....	42
Shooting images (Program Auto mode) .....	44
Focus: Changing the focus method	
Metering Mode: Selecting the metering mode	
ISO: Selecting a luminous sensitivity	
EV: Adjusting the light intensity	

Shooting menu .....	50
REC Mode: Selecting the continuous shooting method	
EV: Adjusting the light intensity	
Focus: Changing the focus method	
Metering Mode: Selecting the metering mode	
White Balance: Adjusting the color tones	
Color Mode: Changing the vividness of the image or adding special effects	
Flash Level: Adjusting the amount of flash light	
Red Eye Reduction: Setting the Red Eye Reduction function	
Face Detection: Detecting the face of subject	
SteadyShot: Selecting the anti-blur mode	
Setup: Selecting the shooting settings	

## Using the viewing functions

Viewing menu .....	58
 (Retouch): Retouching still images	
 (Multi-Purpose Resize): Changing the image size according to usage	
 (Wide Zoom Display): Displaying still images in 16:9	
 (Slideshow): Playing back images in succession along with effects and music	
 (Delete): Deleting images	
 (Protect): Preventing accidental erasure	
DPOF: Adding a Print order mark	
 (Print): Printing images using a printer	
 (Rotate): Rotating a still image	
 (Select Folder): Selecting the folder for viewing images	
 (Volume Settings): Adjusting the volume	

## Customizing the settings

Customizing the Manage Memory feature and the Settings .....	69
 Manage Memory .....	70
 Memory Tool — Memory Stick Tool .....	70
Format	Create REC.Folder
Change REC.Folder	Copy
 Memory Tool — Internal Memory Tool .....	73
Format	
 Settings .....	74
 Main Settings — Main Settings 1 .....	74
Beep	Function Guide
Continuous Play	Initialize
Calibration	
 Main Settings — Main Settings 2 .....	76
USB Connect	CTRL FOR HDMI
Video Out	TV TYPE
 Shooting Settings — Shooting Settings 1 .....	78
AF Illuminator	Grid Line
AF Mode	Digital Zoom
 Shooting Settings — Shooting Settings 2 .....	80
Auto Orientation	Auto Review
 Clock Settings.....	81
 Language Setting .....	82

## Viewing images on a TV

Viewing images on a TV .....	83
------------------------------	----

## Using your computer

Enjoying your Windows computer .....	89
Installing the software (supplied).....	91
On the “Picture Motion Browser” (supplied) .....	93
Copying images to your computer using the “Picture Motion Browser” .....	94
Copying images to your computer without “Picture Motion Browser”.....	98
Viewing image files stored on a computer with the camera copying to the “Memory Stick Duo”.....	100
Using the “Music Transfer” (supplied) .....	101
Using your Macintosh computer .....	102
Viewing “Cyber-shot Step-up Guide” .....	104

## Printing still images

How to print still images .....	105
Printing images directly using a PictBridge compliant printer.....	106
Printing at a shop .....	109

## Troubleshooting

Troubleshooting.....	111
Warning indicators and messages .....	122

## Others

Using the camera abroad — Power sources.....	126
On the “Memory Stick Duo” .....	127
On the battery pack .....	129
On the battery charger .....	130

## Index

Index.....	131
------------	-----

# Basic techniques for better images

Focus

Exposure

Color

Quality

Flash



This section describes the basics so you can enjoy the camera. It tells you how to use various camera functions such as the HOME screen (page 36), and the menus (page 38).

## Focus *Focusing on a subject successfully*

When you press the shutter button halfway down, the camera adjusts the focus automatically (Auto Focus). Remember to press the shutter button only halfway down.

Do not fully press the shutter button straight away.



Press the shutter button halfway down.

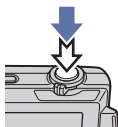

AE/AF lock indicator flashing → lit/beeps



Then press the shutter button fully down.

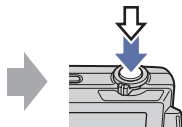

When focusing is difficult → [Focus] (page 44)

If the image looks blurred even after focusing, it may be because of camera shake. → See “Hints for preventing blur” below.

### Hints for preventing blur

The camera moved accidentally when you took the image. This is called “Camera shake.” On the other hand, if the subject moved when you took the image, it is called “subject blur.”

#### Camera shake



#### Cause

Your hands or body shake while you hold the camera and press the shutter button, and the entire screen is blurred.

#### What you can do to reduce the blurring

- Use a tripod or place the camera on a flat surface to hold the camera steady.
- Shoot with a 2-second delay self-timer and stabilize the camera by holding your arms firmly at your side after pressing the shutter button.

#### Subject blur





#### Cause

Even though the camera is steady, the subject moves during the exposure so the subject looks blurred when the shutter button is pressed.

#### What you can do to reduce the blurring

- Select **ISO** (High Sensitivity) mode in Scene Selection.
- Select a higher ISO sensitivity to make the shutter speed faster, and press the shutter button before the subject moves.

#### Notes

- The anti-blur function is enabled in the factory default settings so that the camera shake is reduced automatically. However, this is not effective for subject blur.
- Besides, camera shake and subject blur occur frequently under low-light or slow shutter speed conditions, such as those encountered in  (Twilight) or  (Twilight Portrait) mode. In that case, shoot with the above tips in mind.

### Exposure *Adjusting the light intensity*

You can create various images by adjusting the exposure and the ISO sensitivity. Exposure is the amount of light that the camera will receive when you release the shutter.

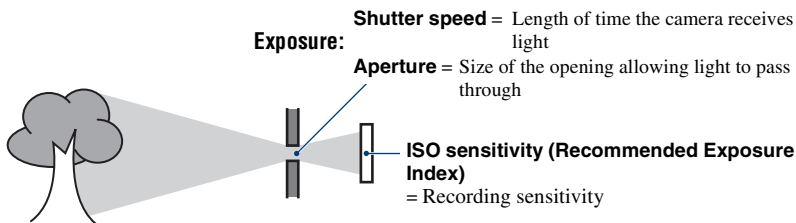

**Overexposure**  
= too much light  
Whitish image



**Correct exposure**

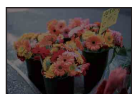

**Underexposure**  
= too little light  
Darker image

The exposure is automatically set to the proper value in the Auto Adjustment mode. However, you can adjust it manually using the functions below.

#### **Adjusting EV:**

Allows you to adjust the exposure determined by the camera (page 49).

#### **Metering Mode:**

Allows you to change the part of the subject to be measured to determine the exposure (page 47).

### Adjusting ISO Sensitivity (Recommended Exposure Index)

ISO sensitivity is a speed rating for recording media that incorporates an image sensor that receives light. Even when the exposure is the same, images differ depending on the ISO sensitivity.

To adjust the ISO sensitivity, see page 48.



#### High ISO sensitivity

Records a bright image even in dark locations while increasing shutter speed to reduce blur.

However, the image tends to become noisy.



#### Low ISO sensitivity

Records a smoother image.





However, when the exposure is insufficient, the image may become darker.

## Color

### On the effects of lighting

The apparent color of the subject is affected by the lighting conditions.

#### Example: The color of an image affected by light sources

Weather/lighting	Daylight	Cloudy	Fluorescent	Incandescent
Characteristics of light	White (standard) 	Bluish 	Green-tinged 	Reddish 

The color tones are adjusted automatically in the Auto Adjustment mode.

However, you can adjust color tones manually with [White Balance] (page 52).

### Quality On “image quality” and “image size”

A digital image is made up of a collection of small dots called pixels. If it contains a large number of pixels, the image becomes large, it takes up more memory, and the image is displayed in fine detail. “Image size” is shown by the number of pixels. Although you cannot see the differences on the screen of the camera, the fine detail and data processing time differ when the image is printed or displayed on a computer screen.

Description of the pixels and the image size

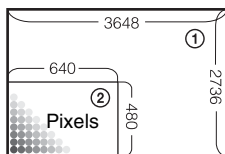





- ① Image size: 10M  
 $3648 \text{ pixels} \times 2736 \text{ pixels} = 9,980,928 \text{ pixels}$
- ② Image size: VGA  
 $640 \text{ pixels} \times 480 \text{ pixels} = 307,200 \text{ pixels}$

### Selecting the image size for use (pages 13, 27, 30)

A diagram illustrating the relationship between image quality and file size. On the left, a photograph of a bird is shown. A blue square on the bird's head is magnified into a grid of pixels. A label "Pixel" points to one of the grid cells. To the right, two circular insets show different levels of detail. The top inset shows a sharp, detailed image of the bird's head, labeled "Many pixels (Fine image quality and large file size)". The bottom inset shows a blurry, low-resolution image of the same bird's head, labeled "Few pixels (Rough image quality but small file size)". Arrows point from these insets to the right, where text provides examples: "Example: Printing in up to A3+ size" for the high-resolution image, and "Example: An attached image to be sent by e-mail" for the low-resolution image.

## Basic techniques for better images

The default settings are marked with ✓.

	Image size	Usage guidelines	No. of images	Printing
✓	<b>4:3</b> 10M 10M (3648×2736)	For prints up to A3+(13×19")	Less 	Fine 
	<b>3:2</b> 8M 3:2 (8M) <sup>*1</sup> (3648×2432)	Shoot in 3:2 aspect ratio	↑ ↓	↑ ↓
	<b>4:3</b> 5M 5M (2592×1944)	For prints up to A4(8×10")		
	<b>4:3</b> 3M 3M (2048×1536)	For prints up to 10×15 cm (4×6") or 13×18 cm(5×7")	↓ 	↓ 
	<b>4:3</b> VGA VGA (640×480)	Shoot at small image size for e-mail attachments		
	<b>16:9</b> 7M 16:9 (7M) <sup>*2</sup> (3648×2056)	For viewing on HDTVs and printing up to A4(8×10")	Less ↑ ↓ More	Fine ↑ ↓ Rough
	<b>16:9</b> 2M 16:9 (2M) <sup>*2</sup> (1920×1080)	For viewing on HDTVs		

\*1) Images are recorded in 3:2 aspect ratio, same as photograph printing paper or postcards, etc.

\*2) Images fill the entire screen. Both edges of the image may be cut off when printing (page 119).

	Movie image size	Average bit rate/ Second	Usage guidelines
✓	<b>7:20</b> FINE 1280×720(Fine)	9 Mbps	Shoot highest quality movie for display on HDTV
	<b>7:20</b> STD 1280×720(Standard)	6 Mbps	Shoot standard quality movie for display on HDTV
	<b>3:VGA</b> FINE VGA	3 Mbps	Shoot at an image size suitable for WEB upload

• The movies shot with this camera will be recorded in MPEG-4 AVC/H.264, Approx. 30fps, Progressive, AAC, mp4 format.

• The larger the image size and average bit rate, the higher the image quality.

• A telephoto image results when the **3:VGA** FINE image size is selected for movies.

### Flash *On using the flash*

The eyes of the subject may come out red, or fuzzy white circular spots may appear when using the flash. These phenomena can be reduced by taking the following steps.

#### The “Red-eye phenomenon”

Pupils become dilated in dark environments. Flash light is reflected off the blood vessels at the back of the eye (retina), causing the “red-eye” phenomenon.

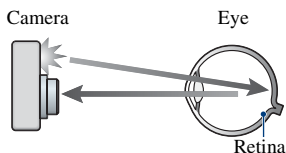

#### How can the “Red-eye phenomenon” be reduced?

- Set [Red Eye Reduction] to [On] (page 55).
- Select **iSO** (High Sensitivity)\* mode in Scene Selection (page 42). (The flash is turned off automatically.)
- When the eyes of the subject turn out red, correct the image with [Retouch] on the viewing menu (page 58) or with the supplied software “Picture Motion Browser”.

#### The “White circular spots”

This is caused by particles (dust, pollen, etc.) floating close to the lens. When they are accentuated by the camera’s flash, they appear as white circular spots.

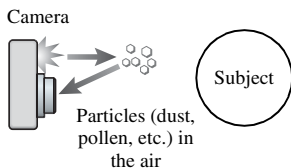

#### How can the “White circular spots” be reduced?

- Light the room and shoot the subject without a flash.
- Select **iSO** (High Sensitivity)\* mode in Scene Selection. (The flash is turned off automatically.)

\* Even though you selected **iSO** (High Sensitivity) mode in Scene Selection, the shutter speed might be slower under low-light conditions, or in a dark place. In that case, use a tripod or hold your arms firmly at your side after pressing the shutter button.

# Identifying parts

See the pages in parentheses for details of operation.

## Camera

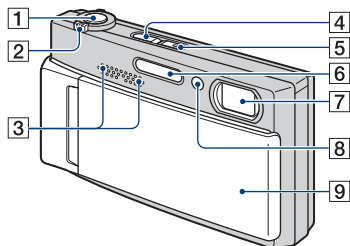

- 1 Shutter button (26)
- 2 Zoom (W/T) lever (27, 30)
- 3 Stereo microphone
- 4 ► (Playback) button (31)
- 5 POWER button/POWER lamp
- 6 Flash (28)
- 7 Lens
- 8 Self-timer lamp (27, 30)/AF illuminator (78)
- 9 Lens cover

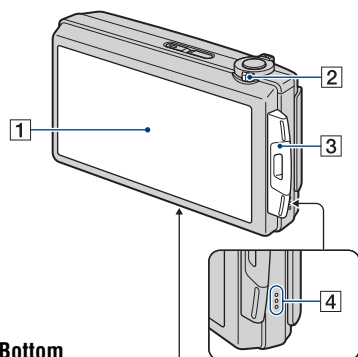

## Bottom

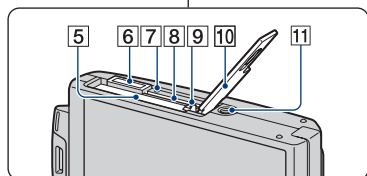

- 1 LCD screen/Touch panel (21, 22)
  - 2 Mode switch (25, 29)
  - 3 Hook for wrist strap/Grip
  - 4 Speaker
  - 5 Battery insertion slot
  - 6 Multi connector
  - 7 Access lamp
  - 8 “Memory Stick Duo” slot
  - 9 Battery eject lever
  - 10 Battery/“Memory Stick Duo” cover
  - 11 Tripod receptacle
- Use a tripod with a screw less than 5.5 mm (7/32 inch) long. Otherwise, you cannot firmly secure the camera, and damage to the camera may occur.

### Multi-output stand

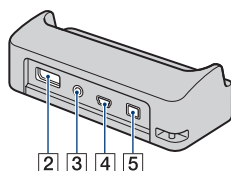
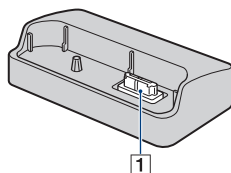

The multi-output stand is used in the following situations by placing the camera in it:

- When connecting the camera and the computer by USB cable.
- When connecting to a TV's audio/video input jacks.
- When connecting to a PictBridge-compliant printer.

**1** Camera connector terminal

**2** HDMI OUT jack (84)

**3** A/V OUT (STEREO) jack (83)

**4** USB jack (94, 106)

**5** DC IN jack

When using an AC-LS5K AC Adaptor (not supplied)

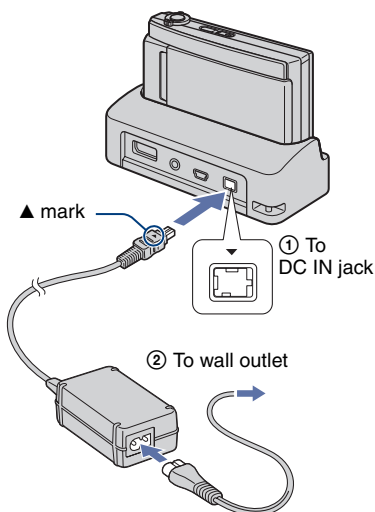

- You cannot charge the battery pack by connecting the camera to the AC-LS5K AC Adaptor. Use the battery charger (supplied) to charge the battery pack.

# Indicators on the screen

Touch [DISP] on the bottom right of the screen to change to the display selection screen (page 22).

See the pages in parentheses for details of operation.

## When shooting still images

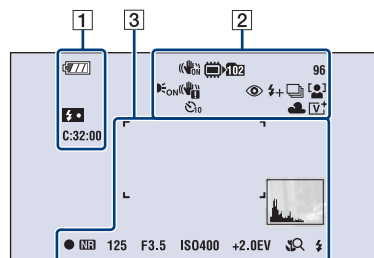

## When shooting movies

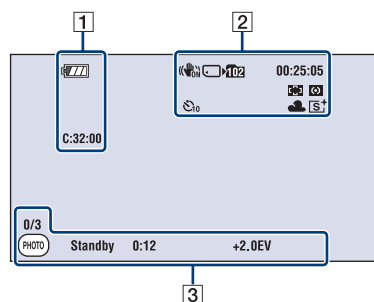

1

Display	Indication
	Battery remaining
	Low battery warning (122)
	Flash charging
<b>C:32:00</b>	Self-diagnosis display (122)
	Zoom scaling (27, 30, 79)
<b>x1.3</b> S Q P Q	

2

Display	Indication
	SteadyShot (57) <ul style="list-style-type: none"> <li>Displayed when the shutter button is pressed halfway in the default settings.</li> </ul>
	Recording Media (“Memory Stick Duo,” internal memory)
	Recording folder (70) <ul style="list-style-type: none"> <li>This does not appear when using internal memory.</li> </ul>
<b>96</b>	Number of recordable images
<b>00:25:05</b>	Recordable time (h:m:s)
	AF illuminator (78)
	Vibration warning <ul style="list-style-type: none"> <li>Indicates vibration may prevent you from shooting clear images due to insufficient lighting. Even if the vibration warning appears, you can still shoot images. However, we recommend that you turn on the anti-blur function, using the flash for better lighting or using a tripod or other means to stabilize the camera (page 9).</li> </ul>
	Red-eye reduction (55)

## Indicators on the screen

Display	Indication
	Flash level (55)
	Recording mode (50)
	Face Detection (56)
	Metering Mode (47)
	Focus (44)
	Touch AF indicator (26)
	Self-timer (27, 30)
	White balance (52)
	Color mode (54)

### 3

Display	Indication
	AF range finder frame (44)
	Histogram (23)
<b>0/3</b>	Still image counter (30)
	Photo button (30)
	AE/AF lock (26)
<b>NR</b>	NR slow shutter <ul style="list-style-type: none"> <li>When the shutter speed becomes slower than a certain speed in low light conditions, the NR (Noise Reduction) slow shutter function is activated automatically to reduce the image noise.</li> </ul>
<b>125</b>	Shutter speed
<b>F3.5</b>	Aperture value
<b>ISO400</b>	ISO number (48)
<b>+2.0EV</b>	Exposure Value (49)

Display	Indication
	Macro/Close focus (28, 30) <ul style="list-style-type: none"> <li>Displayed when [Display Setup] is set to [Image Only].</li> </ul>
	Flash mode (28) <ul style="list-style-type: none"> <li>Displayed when [Display Setup] is set to [Image Only].</li> </ul>
<b>Standby</b> <b>REC</b>	Standby a movie/Recording a movie
<b>0:12</b>	Recording time (m:s)

### When playing back still images

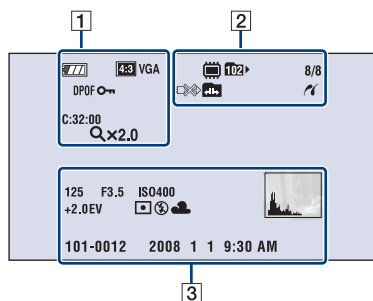

### When playing back movies

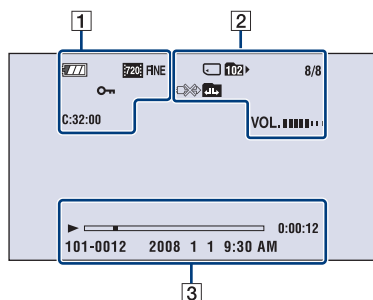







1

Display	Indication
	Battery remaining
	Low battery warning (122)
	Image size (13)
	Print order (DPOF) mark (109)
	Protect (65)
	Self-diagnosis display (122)
	Playback zoom (32)

2

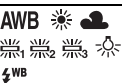
Display	Indication
	Playback Media ("Memory Stick Duo," internal memory)
	Playback folder (67) <ul style="list-style-type: none"> <li>This does not appear when using internal memory.</li> </ul>
	Image number/Number of images recorded in selected folder
	PictBridge connecting (108) <ul style="list-style-type: none"> <li>Do not remove the camera from the multi-output stand or unplug the USB cable while the icon is displayed on the screen.</li> </ul>
	Changing folder (67) <ul style="list-style-type: none"> <li>This does not appear when using internal memory.</li> </ul>
	PictBridge connecting (106)
	Volume (68)

3

Display	Indication
<b>125</b>	Shutter speed
<b>F3.5</b>	Aperture value
<b>ISO400</b>	ISO number (48)
<b>+2.0EV</b>	Exposure Value (49)
	Metering mode (47)
	Flash
<b>AWB</b> 	White balance (52)
	Playback (31)
	Playback bar
<b>0:00:12</b>	Counter
<b>101-0012</b>	Folder-file number (67)
<b>2008 1 1</b> <b>9:30 AM</b>	Recorded date/time of the playback image
	Histogram (23) •  appears when histogram display is disabled.

# Operating the touch panel

This LCD screen also displays the buttons for operating the camera (touch panel).

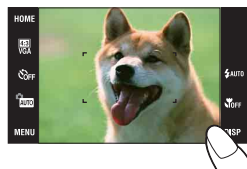
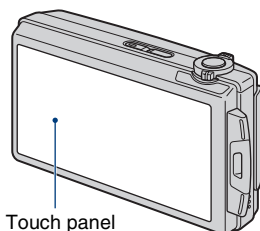

---

## 1 Turn on the camera.

During shooting: Slide the lens cover downward.





During playback: Press  (Playback).

---

## 2 Touch the buttons on the screen lightly with your finger.

---

### On the touch panel buttons

- When the item you want to set is not on the screen, touch /// to change the page.
- You can return to the previous screen by touching [BACK] or [X].
- Touching [OK] advances to the next screen.
- Touching [?] displays the guide about the touched item. To hide this guide, touch [?] again.

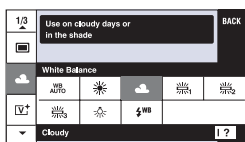

- To operate the touch panel, press it lightly with your finger.
- Do not press against the LCD screen more than necessary.
- If you touch the top right of the screen during shooting, the buttons and icons will momentarily disappear. The buttons and icons will reappear when you take your finger off the screen.

# Changing the screen display

Touch [DISP] on the screen to change to the display selection screen.

- Settings other than [LCD Brightness] should be made separately for shooting and playback.
- In index mode, you can set the number of images displayed (page 32).

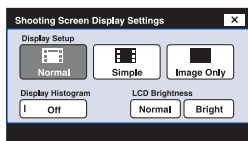
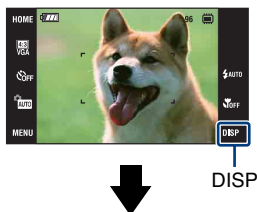

## [Display Setup]

This sets whether or not to display the buttons and icons on the screen.

### Normal

The touch panel buttons and the icons are displayed.



### Simple

Only the touch panel buttons are displayed.



## Image Only



- During playback, touching **OFF** during [Normal] or [Simple] mode temporarily results in an [Image Only] display. To make the touch panel buttons reappear, touch the center.



- During [Image Only] mode, touching the center temporarily results in a [Normal] display. Touch **OFF** to display in [Image Only] again.
- When shooting or playing back in the 16:9 aspect ratio, setting [Image Only] is useful because it fills the entire screen.

### [Display Histogram]

This sets whether or not to display the histogram on the screen.

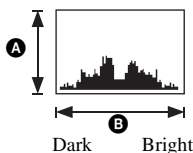
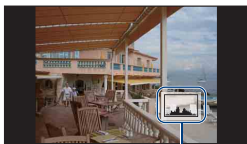

A histogram is a graph showing the brightness of an image. The graph display indicates a bright image when skewed to the right side, and a dark image when skewed to the left side.

- A** Number of pixels
- B** Brightness

- The histogram also appears when playing back a single image, but you cannot adjust the exposure.
- The histogram does not appear in the following situations:
  - While shooting
    - When the menu is displayed.
    - When recording movies
  - During playback
    - When the menu is displayed.
    - In index mode
    - When using playback zoom.
    - When rotating still images.
    - During playback of movies
- A large difference in the histogram displayed during shooting and playback may occur when:
  - The flash strobes.
  - The shutter speed is slow or fast.
- The histogram may not appear for images recorded using other cameras.

### [LCD Brightness]

This sets the backlight brightness.

- When viewing images in bright outside light if [LCD Brightness] is set to [Normal], reset to [Bright].  
However, the battery power may decrease faster under such condition.

# Using the internal memory

The camera has approximately 4 MB of internal memory. This memory is not removable. Even when there is no “Memory Stick Duo” inserted in the camera, you can record images using this internal memory.

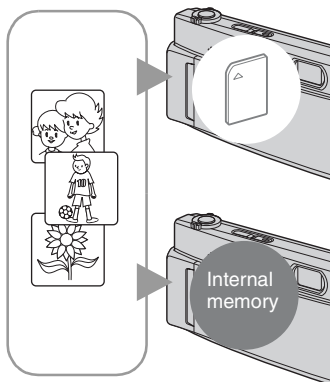

## When a “Memory Stick Duo” is inserted

[Recording]: Images are recorded on the “Memory Stick Duo”.

[Playback]: Images on the “Memory Stick Duo” are played back.

[Menu, Settings, etc.]: Various functions can be performed on images on the “Memory Stick Duo”.

## When there is no “Memory Stick Duo” inserted

[Recording]: Images are recorded using the internal memory.

[Playback]: Images stored in the internal memory are played back.

[Menu, Settings, etc.]: Various functions can be performed on images in the internal memory.

## On image data stored in the internal memory

We recommend that you copy (back up) data without error using one of the following methods.

### To copy (back up) data on a “Memory Stick Duo”

Prepare a “Memory Stick Duo” with sufficient free capacity, then perform the procedure explained in [Copy] (page 72).

### To copy (back up) data on a hard disk of your computer

Perform the procedure on pages 94 to 99 without a “Memory Stick Duo” inserted in the camera.

- You cannot copy image data on a “Memory Stick Duo” to the internal memory.
- By connecting the camera to a computer with a USB cable, you can copy data stored in the internal memory to a computer. However you cannot copy data on a computer to the internal memory.



# Shooting still images

The procedure for shooting still images using the basic functions is given below.

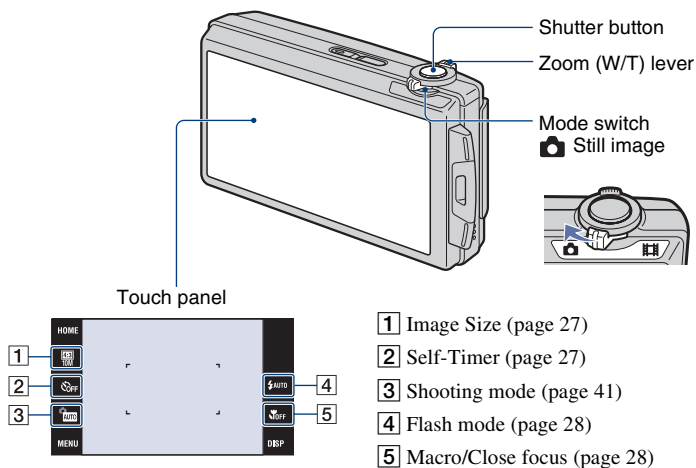

---

**1** Set the mode switch to (still image).

---

**2** Open the lens cover.

---





**3** Hold the camera steady, keeping your arms at your side.



Position the subject in the center of the focus frame or touch the point for focusing.

 You can touch the screen to select the point to bring into focus.

Touching the subject on the touch panel displays a frame, and then pressing the shutter button halfway down brings the frame into focus. If there is a face in the frame, in addition to the focus, the brightness and hue are also automatically optimized.

-  is displayed on the top right of the screen if a face is detected at the touched position or  is displayed if an object other than a person's face is detected. Touch  OFF to cancel this function.
- This function cannot be used in  (Close focus enabled) mode or during digital zoom.
- You can use this function when the shooting mode for still image is set to **AUTO** (Auto Adjustment), **PGM** (Program Auto) or  (Soft Snap) mode.
- If you touch outside the selectable focus range, the selectable range is displayed.

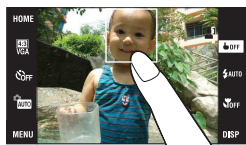

## 4 Shoot with the shutter button.

- ① Press and hold the shutter button halfway down to focus.

The  (AE/AF lock) indicator (green) flashes, a beep sounds, the indicator stops flashing and remains lit.



AE/AF lock indicator

- ② Press the shutter button fully down.

### If you shoot a still image of a subject that is difficult to focus on

- The shortest shooting distance is approximately 50 cm (19 3/4 inches) (W), 80 cm (31 1/2 inches) (T) (from the lens). Shoot in the close-up (Macro) mode or Close focus mode when you shoot a subject closer than the shooting distance.
- When the camera cannot focus on the subject automatically, the AE/AF lock indicator changes to flash slowly and the beep does not sound. Recompose the shot and focus again.

Focusing may be difficult in the following situations:

- It is dark and the subject is distant.
- The contrast between the subject and the background is poor.
- The subject is seen through glass.
- The subject is moving quickly.
- There is reflective light or shiny surfaces.
- The subject is backlit or there is a flashing light.

### W/T Using the zoom

Slide the zoom (W/T) lever to the T side to zoom and slide to the W side to return.

- When the zoom scale exceeds 5 $\times$ , the camera uses the Digital Zoom function.

For details on the [Digital Zoom] settings and the image quality, see page 79.

### Changing the image size

Touch the image size setting button on the screen. Touch the desired item, then [BACK].  
For details on the image size, see page 12.

### Using the self-timer

Touch the self-timer setting button on the screen. Touch the desired item, then [BACK].

 : Not using the self-timer

 : Setting the 10-second delay self-timer

 : Setting the 2-second delay self-timer

When you press the shutter button, the self-timer lamp flashes and a beep sounds until the shutter operates.

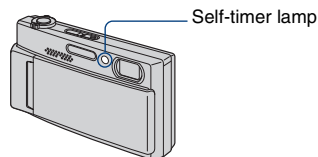

To cancel, touch .

- Use the 2-second delay self-timer to prevent blur of an image. The shutter is released 2 seconds after you press the shutter button, which reduces camera shake when the shutter button is pressed.

### Flash (Selecting a flash mode for still images)

Touch the flash mode setting button on the screen. Touch the desired item, then [BACK].

 AUTO: Flash Auto

Flashes when there is insufficient light or backlight (default setting)

 : Flash forced on

 SL: Slow Synchro (Flash forced on)

The shutter speed is slow in a dark place to clearly shoot the background that is out of flash light.

 : Flash forced off

- The flash strobos twice. The first flash adjusts the light quantity.
- While charging the flash,  is displayed.

### Macro/Close focus enabled (Shooting close-up)

Touch the Macro/Close focus setting button on the screen. Touch the desired item, then [BACK].

 OFF: Macro Off

 : Macro On

W side: Approx. 8 cm or farther (3 1/4 inches or farther)

T side: Approx. 80 cm or farther (31 1/2 inches or farther)

 : Close focus enabled

Locked to the W side: Approximately 1 to 20 cm (13/32 to 7 7/8 inches)

Use this mode to shoot at even closer distances than Macro recording.

- The Auto Focus speed becomes slower when you shoot images in the Macro or Close focus mode.

#### Macro

- Setting the zoom all the way to the W side is recommended.

#### Close focus

- The optical zoom is locked to the W side and cannot be used.
- You cannot shoot images in the Burst or Bracket mode (page 50).
- You cannot use the Face Detection function when you shoot images in the Close focus mode.
- This mode is cancelled if you turn off the power or switch the mode to another one.

# Shooting movies

The procedure for shooting movies using the basic functions is given below.

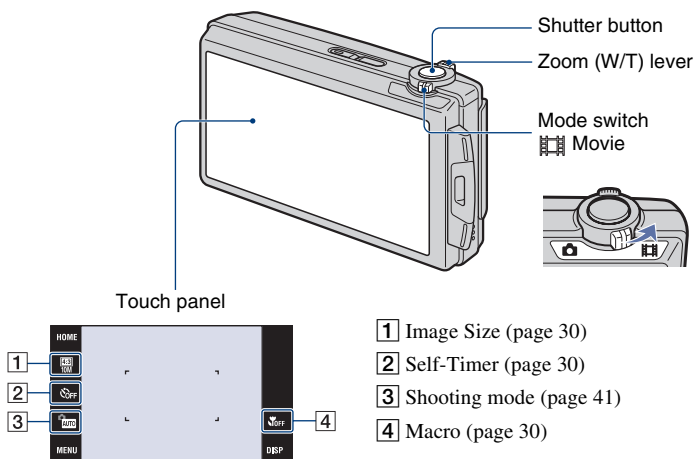

---

**1** Set the mode switch to  (movie).

---

**2** Open the lens cover.

---

**3** Press the shutter button.

The recording starts.



- [REC] is displayed on the screen during recording.
- 

## To stop the movie recording

Press the shutter button again.



 To shoot the still images during recording the movies

You can shoot the still images by touching the  (Photo button) when recording the movies only when "Memory Stick Duo" (not supplied) is inserted into the camera.



Still image counter

Photo button

- You can shoot up to three still images while shooting a single movie.
-  0.9M (approx. 0.9 MB) is used as the recording size for still images when shooting in [1280×720] mode, while  VGA is used when shooting in [VGA] mode.

### W/T Using the zoom

Slide the zoom (W/T) lever to the T side to zoom and slide to the W side to return.

- The camera zooms slowly while shooting a movie.

### Changing the image size

Touch the image size setting button on the screen. Touch the desired item, then [BACK]. For details on the image size, see page 12.

### Using the self-timer

Touch the self-timer setting button on the screen. Touch the desired item, then [BACK].

 OFF : Not using the self-timer

 10 : Setting the 10-second delay self-timer

 2 : Setting the 2-second delay self-timer

### Macro (Shooting close-up)

Touch the Macro setting button on the screen. Touch the desired item, then [BACK].

 OFF : Macro Off

 ON : Macro On

W side: Approx. 8 cm or farther (3 1/4 inches or farther)

T side: Approx. 80 cm or farther (31 1/2 inches or farther)

- Setting the zoom all the way to the W side is recommended.

# Viewing images

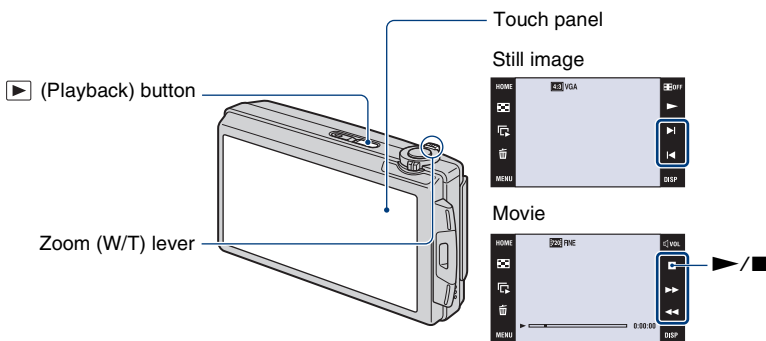

## 1 Press **▶** (Playback) button.

- If you press **▶** (Playback) when the camera is powered off, the camera is turned on and set to playback mode. To switch to the shooting mode, press **▶** (Playback) again.

## 2 Touch **◀** (previous)/**▶** (next) to select an image.

Touch **▶** to play back a movie.

Fast forward/fast rewind: **▶▶**/**◀◀**

Volume control: Touch **◀vol** during movie playback, then adjust the volume with **◀+ / ▶-**.  
Touch **[Exit]** to turn off the volume control screen.

Stop: Touch **■**.

- You can start continuous playback by touching **▶** when **[Continuous Play]** is set to **[On]**; when **[Continuous Play]** is **[Off]**, **▶** is used as the movie playback button.



Movie playback/**[Continuous Play]** button (page 33)

You can turn this function on/off from the HOME screen, **⚙** (Settings) → **[⚙ Main Settings 1]** → **[Continuous Play]** (page 74).



- When **[Display Setup]** is set to **[Image Only]**, touch the right/left side of the screen during still image playback to display the next/previous image, and touch the center of the screen to display in **[Normal]** mode. Touch **⏻OFF** to display in **[Image Only]** again.

- You cannot play back the movies shot using another camera.

### To view an enlarged image (playback zoom)

Touch a still image while it is displayed to enlarge the corresponding area.

▲/▼/◀/▶: Adjusts the position.

 : Changes the zoom scale.

: Turns ▲/▼/◀/▶ on/off.

BACK: Cancels playback zoom.

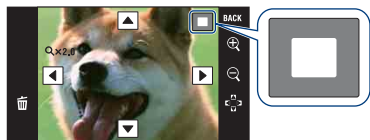



Shows the displayed area of the whole image  
In this case, the center is enlarged.

- To store enlarged images, see [Trimming] (page 58).
- When playing back in [Image Only] mode, touch the center of the screen to set to [Normal] display and then touch the screen again (page 22).

You can also enlarge the image by sliding the zoom (W/T) lever to the T side. Slide the lever to the W side to return.

### To view an index screen (Image Index)

Touch  (Index) to display the index screen.

Touch  /  to display the previous/next page.



 (Index)

To return to the single-image screen, touch the thumbnail image on the index screen.

- If you touch [DISP] in index mode, you can set the number of images displayed in the index screen to 6 or 20 images.
- In single-image mode, you can display the index screen by sliding the zoom (W/T) lever to the W side.

## To playback the slideshow

Touch  (Slideshow).



Slideshow

To end the slideshow, touch the panel, and then touch [Exit].

To change the slideshow settings, see page 61.

## To adjust the volume of the music

Touch the panel to display the volume control screen, then adjust the volume with  $\uparrow/\downarrow$ . Touch [x] to turn off the volume control screen.

- You can adjust the volume from the  (Volume Settings) in [MENU], before the playback starts.

## To view files using continuous playback

This camera can provide continuous playback of files that have been shot. This function is useful when playing several movie files together.



Movie0001

Movie0002

Still image0003

Movie0004

- Touch  to display the file you want to begin continuous playback from.



② Touch **▶**.

The continuous playback starts.

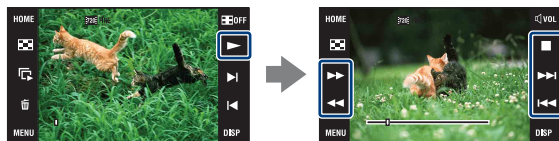

Touch **▶▶** to fast forward, **◀◀** to fast rewind.

Touch **■** to stop. Touch **▶** to start the continuous playback again.

### To view the next file during continuous playback

Touching **▶▶|** advances to the start of the next file.

### To view the previous file during continuous playback

Touching **|◀◀** returns to the start of the file being played. Double touching **◀◀** returns the sequence of images to the start of the previous file.

# Deleting images

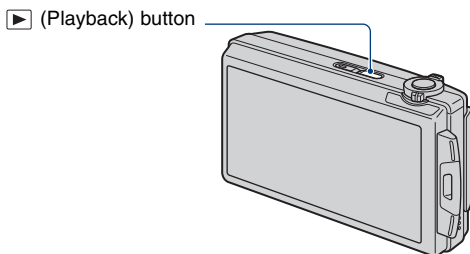

**1** Press ▶ (Playback) button.

**2** Display the image you want to delete, then touch  (Delete).





**3** Touch [OK].

## When you delete images from the index screen

- ① Touch  (Delete) while displaying in index mode.
- ② Touch the image you want to delete.  
✓ mark is checked in the check box of the image.



✓ mark  
Touch ✓ again to remove the marks.

- Touch  on the index screen to return to the single-image screen.
- ③ Touch , then touch [OK].
- To delete all the images, see page 63.

# Learning the various functions – HOME/Menu

## Using the HOME screen

The HOME screen is the gateway screen for all the functions of the camera, and can be called up regardless of the mode setting (shooting/viewing).

### 1 Touch [HOME] to display the HOME screen.

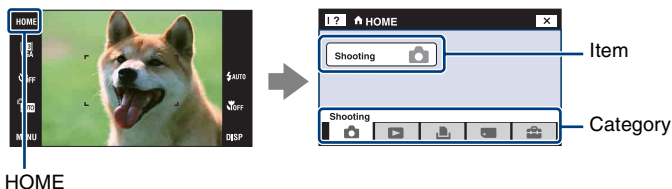

### 2 Touch the category you want to set.

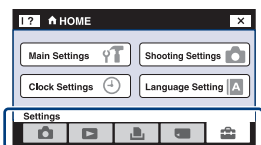

### 3 Touch the item in the category you want to set.







- If the function guide is displayed, touch [OK] to confirm.

- You cannot display the HOME screen under the following situations:
  - During TV output
  - When a PictBridge connection is made.
  - When a USB connection is made.
- The camera is set to the shooting mode by pressing the shutter button halfway down.
- Touch [x] to return to the previous screen.

## HOME items

Touching [HOME] displays the following items.  
 Only the available items are displayed on the screen.  
 Details on each item are displayed in the guide at the bottom of the screen.

Categories	Items
 Shooting*	Shooting (page 41)
 View Images	Single Image (page 31) Image Index (page 32) Slideshow (page 61)
 Printing, Other	Print (page 106) Music Tool (page 101) Download Music                      Format Music
 Manage Memory	Memory Tool Memory Stick Tool (page 70) Format                      Create REC.Folder Change REC.Folder              Copy Internal Memory Tool (page 73) Format
 Settings	Main Settings Main Settings 1 (page 74) Beep                      Function Guide Continuous Play              Initialize Calibration Main Settings 2 (page 76) USB Connect                      CTRL FOR HDMI Video Out                      TV TYPE
	Shooting Settings Shooting Settings 1 (page 78) AF Illuminator                      Grid Line AF Mode                      Digital Zoom Shooting Settings 2 (page 80) Auto Orientation                      Auto Review
	Clock Settings (page 81)
	Language Setting (page 82)

\* Shooting mode selected with the mode switch (page 41) will be applied.

## Using the menu items

### 1 Touch [MENU] to display the menu.



MENU

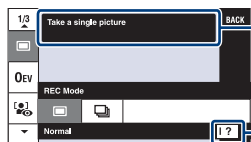

Guide

You can turn this guide on or off by touching [?].

- Different items will become visible depending on the selected mode.

### 2 Touch the desired menu item.

- If the desired item is hidden, keep touching ▲/▼ until the item appears on the screen.

### 3 Touch the desired setting item.

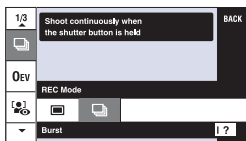

### 4 Touch [BACK] to turn off the menu.

# Menu items

The available menu items vary depending on the mode setting (shooting/viewing) and the shooting mode.

Only the available items are displayed on the screen.

(✓ : available)

Selected mode	Still image mode			Movie mode	
		AUTO	SCN	PGM	AUTO

## Shooting menu (page 50)

REC Mode	✓	✓ <sup>*1</sup>	✓	—	—
EV	✓	✓	— <sup>*2</sup>	✓	✓
Focus	—	—	— <sup>*2</sup>	✓	✓
Metering Mode	—	—	— <sup>*2</sup>	✓	—
White Balance	—	✓ <sup>*1</sup>	✓	✓	✓
Color Mode	—	—	✓	✓	—
Flash Level	—	—	✓	—	—
Red Eye Reduction	✓	✓ <sup>*1</sup>	✓	—	—
Face Detection	✓	✓ <sup>*1</sup>	✓	—	—
SteadyShot	—	✓	✓	✓	✓
Setup	✓	✓	✓	✓	✓

<sup>\*1</sup> The operation is limited according to the selected Scene Selection mode (page 43).

<sup>\*2</sup> These items appear on the bottom of the screen in [Program Auto] mode (page 44).

### Viewing menu (page 58)

---

 (Retouch)

 (Wide Zoom Display)

 (Delete)

**DPOF**

 (Rotate)

 (Volume Settings)

 (Multi-Purpose Resize)

 (Slideshow)

 (Protect)

 (Print)

 (Select Folder)



# Switching the shooting mode

You can switch the shooting mode.

There are three shooting modes available for still images: Auto Adjustment, Program Auto, Scene Selection; and there are two recording modes for movies: Auto Adjustment and High Sensitivity. The default setting is Auto Adjustment.

To switch the shooting mode to other than Auto Adjustment, follow the procedure described below.

- 1 Select the shooting mode by mode switch.

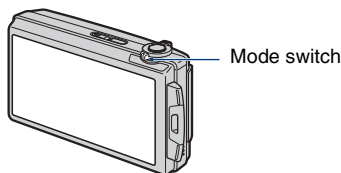
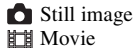

- 2 Touch the shooting mode setting button.
- 3 Touch the desired mode.
- 4 Touch [BACK] to turn off the setup screen.

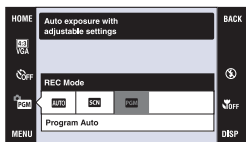

## Still image mode

### **AUTO**: Auto Adjustment

Allows you to shoot still images with the setting adjusted automatically.

### **SCN**: Scene Selection

Allows you to shoot with preset settings according to the scene (page 42).

### **PGM**: Program Auto

Allows you to shoot with the exposure adjusted automatically (both the shutter speed and the aperture value). Also you can select various settings using the menu. (For details on the functions available, see page 39.) The setting buttons for Focus, Metering mode, ISO and EV will appear on the bottom of the screen (page 44).

## Movie mode

### **AUTO**: Auto Adjustment

Allows you to shoot movies easily with the setting adjusted automatically.

### **ISO**: High Sensitivity

Allows you to shoot movies using settings appropriate for a dark location.

# Shooting images according to the scene mode

## Modes for still images (Scene Selection)

The following modes are preset to match the scene conditions.



### ISO High Sensitivity

Allows you to shoot images without a flash under low light conditions, reducing blur.



### Beach

Allows you to record the blue of the water clearly when shooting seaside or lakeside scenes.



### Snow

Allows you to record clear images preventing sunken colors in snowy scenes or other places where the whole screen appears white.



### Soft Snap

Allows you to shoot images with a softer atmosphere for portraits and flowers, etc.



### Fireworks\*

Allows you to record fireworks in all their splendor.



### Landscape

Focuses only on a distant subject to shoot landscapes, etc.



### Hi-Speed Shutter

Allows you to capture fast moving subjects outdoors or in other bright places.





### Twilight Portrait\*

Allows you to shoot sharp images of people with the night view in the background without compromising the atmosphere.



### Twilight\*

Allows you to shoot night scenes at far distance without losing the dark atmosphere of the surroundings.

\*When you shoot images using  (Twilight Portrait),  (Twilight) or  (Fireworks) mode, the shutter speed is slower and the images tend to blur. To prevent blurring, the use of a tripod is recommended.

### Modes for movies



















#### High Sensitivity

Allows you to shoot movies in a natural ambience even in dark places.

### Functions you can use in Scene Selection

For shooting an image appropriately according to the scene condition, a combination of functions is determined by the camera. Some functions are not available, depending on the Scene Selection mode.

(✓: you can select the desired setting)

	Macro/ Close Focus	Flash	Face Detection	Burst/ Bracket	EV	White Balance	Red Eye Reduction
	✓/—		—	—	✓	✓*	—
	✓/—	✓	✓	✓	✓	—	✓
	—/—		—	✓	✓	—	✓
	✓/—	 SL	—	—	✓	—	✓
	—/—		—	—	✓	—	—
	✓/—		—	✓	✓	—	✓
	✓/—		—	✓	✓	—	✓
	—/—		—	—	✓	—	—
	✓/—		—	✓	✓	—	✓

\*[Flash] for [White Balance] cannot be selected.

# Shooting images (Program Auto mode)

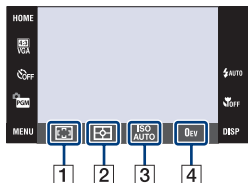

The Focus, Metering Mode, ISO and EV buttons appear only when the shooting mode is set to PGM (Program Auto).



- 1 Focus (page 44)
- 2 Metering Mode (page 47)
- 3 ISO (page 48)
- 4 EV (page 49)

## Focus: Changing the focus method

You can change the focus method. Use the menu when it is difficult to get the proper focus in auto focus mode.

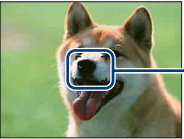
✓	 (Multi AF)	<p>Focuses on a subject in all ranges of the finder frame automatically.</p> <ul style="list-style-type: none"><li>This mode is useful when the subject is not in the center of the frame.</li></ul>  <p>AF range finder frame (Only for still image)</p>
	 (Center AF)	<p>Focuses on a subject in the center of the finder frame automatically.</p> <ul style="list-style-type: none"><li>Using the AF lock function together, you can compose the image the way you want.</li></ul>  <p>AF range finder frame</p>

	<p> <input checked="" type="checkbox"/> (Spot AF)         </p>	<p>Focuses on an extremely small subject or a narrow area automatically.</p> <ul style="list-style-type: none"> <li>Using the AF lock function together, you can compose the image the way you want. Hold the camera steady so as not to misalign the subject and the AF range finder frame.</li> </ul>  <p>AF range finder frame</p>
1.0 m		<p>Focuses on the subject using a previously set distance to the subject. (Focus preset)</p> <ul style="list-style-type: none"> <li>When shooting a subject through a net or through window glass, it is difficult to get the proper focus in auto focus mode. In these cases, use of the focus preset is convenient.</li> </ul>
3.0 m		
7.0 m		
$\infty$ (unlimited distance)		

- AF stands for Auto Focus.
- Regardless of which mode is set, touching the screen will bring that part into focus (page 26).
- When you use [Digital Zoom] or [AF Illuminator], the AF range finder frame is disabled and appears in a dotted line. In this case, the camera works to focus on the subjects at the center of the screen.
- You can change the focus method only when [Face Detection] is set to [When touched].
- You can select only [Multi AF], [1.0 m], [3.0 m], [7.0 m] or [ $\infty$ ] when shooting movies.
- The focus preset distance setting contains some error, and this error increases when the zoom is set to the T side or the lens is tilted upward or downward.

## Shooting images (Program Auto mode)

### 💡 If the subject is out of focus

When shooting with the subject at the edge of the frame (or the screen), or when using [Center AF] or [Spot AF], the camera may not focus on a subject at the edge of the frame.



In such cases, do as follows:

- ① Recompose the shot so that the subject is centered in the AF range finder, and press the shutter button halfway down to focus on the subject (AF lock).

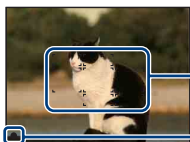

AF range finder frame

AE/AF lock indicator

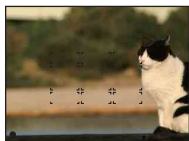

As long as you do not press the shutter button fully down, you can retry the procedure as many times as you want.

- ② When the AE/AF lock indicator stops flashing and remains on, return to the fully composed shot, and press the shutter button fully down.



### Metering Mode: Selecting the metering mode

Selects the metering mode that sets which part of the subject to measure to determine the exposure.

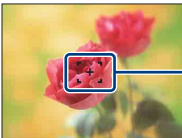
✓	 (Multi)	Divides into multiple regions and measures each region. The camera determines a well-balanced exposure (Multi-pattern metering).
	 (Center)	Measures the center of the image, and determines the exposure based on the brightness of the subject there (Center-weighted metering).
	 (Spot) (Only for still image)	Measures only a part of the subject (Spot metering). <ul style="list-style-type: none"> <li>This function is useful when the subject is backlit or when there is strong contrast between the subject and the background.</li> </ul> <div data-bbox="415 550 609 695">  </div> <p data-bbox="636 608 881 656">Spot metering cross hairs Positions on the subject</p>

- For details on the Exposure, see page 10.
- When using spot metering or center-weighted metering, setting [Focus] to [Center AF] is recommended to focus on the metering position (page 44).
- You can select the metering mode only when [Face Detection] is set to [When touched].
- The metering mode is fixed to [Multi] when you touch the screen to select the point to bring into focus (page 26).

### ISO: Selecting a luminous sensitivity

Sets the ISO sensitivity.



Low ISO sensitivity



High ISO sensitivity

✓	ISO AUTO (Auto)	You can reduce image blurring in dark locations or moving subjects by increasing ISO sensitivity (select a larger number). However, images tend to become noisier as the ISO sensitivity number increases. Select an ISO sensitivity number according to shooting conditions.
	ISO 80	
	ISO 100	
	ISO 200	
	ISO 400	
	ISO 800	
	ISO 1600	
	ISO 3200	

- For details on the ISO sensitivity, see page 11.
- You can select only from [ISO AUTO], [ISO 80] to [ISO 800] when set to Burst or Exposure Bracket.
- When shooting under bright conditions, the camera automatically enhances tones to prevent images appearing pale. (Excludes when [ISO] is set to [ISO 80])

### EV: Adjusting the light intensity

Manually adjusts the exposure.

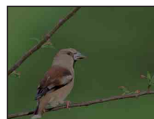

Toward -



Toward +

	-2.0EV	Toward -: Darkens an image.
✓	0EV	The exposure is determined automatically by the camera.
	+2.0EV	Toward +: Brightens an image.

- For details on the Exposure, see page 10.
- The compensation value can be set in 1/3EV increments.
- If you shoot a subject in extremely bright or dark conditions, or when you use the flash, the exposure adjustment may not be effective.

The available mode switch positions are indicated as shown below. For details on how to operate the menu, see page 38.









The default settings are marked with .

## REC Mode: Selecting the continuous shooting method



Selects whether the camera performs continuous shooting or not when you press the shutter button.

	 (Normal)	Does not shoot continuously.
	 (Burst)	<p>Records 100 images in succession when you press and hold down the shutter button.</p>  <ul style="list-style-type: none"> <li>The flash is set to  (Flash forced off).</li> </ul>
	BRK±0.3EV	<p>Records a series of three images with the exposure values automatically shifted (Exposure Bracket). The larger the bracket step value, the larger the shift of the exposure value.</p> <ul style="list-style-type: none"> <li>When you cannot decide the correct exposure, shoot in the Exposure Bracket mode, shifting the exposure value. You can select the image with the best exposure afterward.</li> </ul>  <ul style="list-style-type: none"> <li>When the shooting mode for still image is set to <b>AUTO</b> (Auto Adjustment), the Exposure Bracket mode is not available.</li> <li>The flash is set to  (Flash forced off).</li> </ul>
	BRK±0.7EV	
	BRK±1.0EV	

### On the Burst

- When recording with the self timer, a series of a maximum of five images is recorded.
- The recording interval is approximately 0.74 seconds. The recording interval becomes longer, depending on the setting for the image size.
- When the battery level is low, or when the internal memory or “Memory Stick Duo” is full, the Burst stops.
- You may not be able to shoot images in the Burst mode depending on the Scene Selection mode (page 43).
- The focus, white balance, and exposure are adjusted for the first image, and these settings are also used for the other images.

### On the Exposure Bracket

- The focus and white balance are adjusted for the first image, and these settings are also used for the other images.
- When you adjust the exposure manually (page 49), the exposure is shifted based on the adjusted brightness.
- The recording interval is the same as that for Burst mode, but becomes slower depending on the shooting conditions.
- If the subject is too bright or too dark, you may not be able to shoot properly with the selected bracket step value.
- You may not be able to shoot images in the Exposure Bracket mode depending on the Scene Selection mode (page 43).

## EV: Adjusting the light intensity

Manually adjusts the exposure. This menu is the same as the menu that appears when you touch the EV setting button in  (Program Auto) mode. See page 49.

## Focus: Changing the focus method

You can change the focus method. Use the menu when it is difficult to get the proper focus in Auto Focus mode. This menu is the same as the menu that appears when you touch the Focus setting button in  (Program Auto) mode. See page 44.









## Metering Mode: Selecting the metering mode





Selects the metering mode that sets which part of the subject to measure to determine the exposure. This menu is the same as the menu that appears when you touch the Metering Mode setting button in  (Program Auto) mode. See page 47.

## White Balance: Adjusting the color tones



Adjusts color tones according to the surrounding light conditions. Use this function if image color appears unnatural.











✓	 (Auto)	Adjusts the White Balance automatically.
	 (Daylight)	Adjusts for outdoors conditions on a fine day, evening views, night scenes, neon signs, fireworks, etc.  
	 (Cloudy)	Adjusts for a cloudy sky or a shady location.  
	 (Fluorescent Light 1)/  (Fluorescent Light 2)/  (Fluorescent Light 3)	Fluorescent Light 1: Adjusts for white fluorescent lighting. Fluorescent Light 2: Adjusts for natural white fluorescent lighting. Fluorescent Light 3: Adjusts for day white fluorescent lighting.  

	 (Incandescent)	<p>Adjusts for places under incandescent lamp, or under bright lighting, such as in a photo studio.</p> 
	 (Flash)	<p>Adjusts for the flash conditions.</p> <ul style="list-style-type: none"> <li>You cannot select this item when shooting movies.</li> </ul> 

- For details on the white balance, see page 11.
- Under fluorescent lights that flicker, the white balance function may not work correctly even though you select [Fluorescent Light 1], [Fluorescent Light 2] or [Fluorescent Light 3].
- When shooting with a flash in other than [Flash] mode, [White Balance] is set to [Auto].
- Some options are not available depending on the Scene Selection mode (page 43).

**Color Mode: Changing the vividness of the image or adding special effects**

You can change the brightness of the image, accompanied by effects.





✓	 (Normal)	Sets the image to standard color. 
	 (Vivid)	Sets the image to bright and deep color. 
	 (Natural)	Sets the image to quiet color. 
	 (Sepia)	Sets the image to sepia color. 
	 (B & W)	Sets the image to black and white. 

- You can select only [Normal], [Sepia] or [B & W] when shooting movies in Auto Adjustment mode.

## Flash Level: Adjusting the amount of flash light



Adjusts the amount of flash light.



	(-)	Toward -: Makes the flash level lower.
	 (Normal)	
	(+)	Toward +: Makes the flash level higher.

- To change flash mode, see page 28.
- Sometimes effects do not show up when the subject being shot is too bright or too dark.

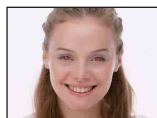
## Red Eye Reduction: Setting the Red Eye Reduction function



The flash strobos two or more times before shooting to reduce the red-eye phenomenon when using the flash.

	(Auto)	When the Face Detection function is activated, the flash strobos automatically to reduce the red-eye phenomenon.
	(On)	The flash always strobos to reduce the red-eye phenomenon.
	(Off)	Does not use Red Eye Reduction.



- To avoid blurring of images, hold the camera firmly until the shutter is released. It usually takes a second after you press the shutter button. Be also sure not to allow the subject to move during this period.
- Red Eye Reduction may not produce the desired effects. It depends on individual differences and conditions, such as distance to the subject, or if the subject looked away from the pre-strobe. In such a case, you can correct the red-eye using  (Retouch) in the viewing menu after shooting (page 58).
- If you do not use the Face Detection function, Red Eye Reduction does not work, even when you select [Auto].
- This setting is not available depending on the Scene Selection mode (page 43).



## Face Detection: Detecting the face of subject

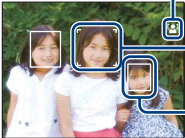

Selects whether to use the Face Detection function continuously or when the touch panel is touched.



Detecting the faces of your subject will also adjust focus, strobe, exposure, white balance, and pre-strobe for red-eye reduction.

	 (Continuous)	<p>Detects the face the camera is to automatically focus on.</p>  <ul style="list-style-type: none"> <li>— Face Detection mark</li> <li>— Face Priority frame</li> <li>— Face Detection frame</li> </ul> <ul style="list-style-type: none"> <li>• Touching the face changes the Face Detection frame to the Face Priority frame. If the subject area you touch is not a face, the section near the touched area is brought into focus.</li> </ul>
✓	 (When touched)	<p>Touch the screen, and if a face is detected, operation is the same as [Continuous].</p>

- When the Face Detection function is activated
  - You cannot use the AF illuminator.
  - You cannot use the Digital Zoom function.
- In  (Soft Snap) mode, the default setting is [Continuous].
- The camera can detect up to 8 subject faces. However, in  (Soft Snap) mode, it can detect only up to 4 subject faces.
- When the camera detects more than one subject, the camera will judge which is the main subject and set focus by priority.
- The frame which the focus is set will turn green by pressing the shutter button half way down. Even when the frame does not turn green, if the distance of the subject which the focus is set on and other subjects are the same, the focus is set on all subjects.
- When the shooting mode for still image is a mode other than **AUTO** (Auto Adjustment), **PGM** (Program Auto), and  (Soft Snap) mode, the Face Detection function is always off.
- Faces may not be detected correctly when:
  - It is too dark or too bright.
  - Faces are partially hidden by sunglasses, masks, hats, etc.
  - The subjects are not facing the camera.



**SteadyShot: Selecting the anti-blur mode**

Selects the anti-blur mode.

<input checked="" type="checkbox"/>  (Shooting)	Activates the anti-blur function when pressing the shutter button halfway down.
<input type="checkbox"/>  (Continuous)	Always activates the anti-blur function. You can stabilize images even when zooming up a far subject. <ul style="list-style-type: none"> <li>• Battery consumption is faster than in [Shooting] mode.</li> </ul>
<input type="checkbox"/>  (Off)	Does not use anti-blur mode.

- If you shoot still images in **AUTO** (Auto Adjustment) mode, [SteadyShot] is set to [Shooting].
- For movies, you can set [Continuous] or [Off] only. The default setting is set to [Continuous].
- The anti-blur function may not work properly in the following cases.
  - When camera shake is too strong
  - When the shutter speed is slow, for example, shooting night scenes

**Setup: Selecting the shooting settings**

Selects the settings for the shooting function. The items appearing in this menu are the same ones as those in  Shooting Settings] in  (Settings) on the HOME screen. See pages 37, 78.





This section explains the menu items available when you touch [MENU] in playback mode. For details on how to use the menu, see page 38.





## (Retouch): Retouching still images



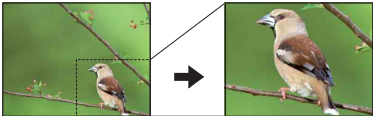

Adds effects or makes corrections to a recorded image and records it as a new file. The original image is retained.

### To retouch the still images

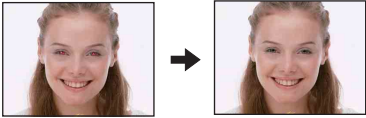
- ① Select the images you want to retouch while displaying in single-image mode.
- ② Touch [MENU].
- ③ Touch , then touch the desired mode.
- ④ Retouch the images following the instructions for each retouching mode below.

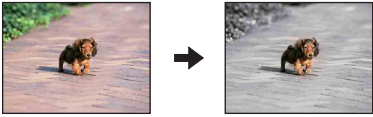
- Touching [OK] in the Retouch screen enables checking of the effects that are currently set (except for  (Trimming) and  (Red Eye Correction)).





 (Trimming)	<p>Records the zoomed playback image.</p>  <ol style="list-style-type: none"> <li>① Touch the image or slide the zoom (W/T) lever to zoom in on the trimming range.</li> <li>② Set the point with ▲/▼/◀/▶, then touch .</li> <li>③ Select an image size to record with ◀/▶, then touch .</li> <li>④ Touch [OK].</li> </ol> <ul style="list-style-type: none"> <li>• The quality of trimmed images may deteriorate.</li> <li>• The image size that you can trim may vary depending on the image.</li> </ul>
 (Red Eye Correction)	<p>Corrects the red-eye phenomenon caused by flash.</p>  <p>After red eye correction is completed, touch [OK].</p> <ul style="list-style-type: none"> <li>• You may not be able to correct the red-eye phenomenon depending on the image.</li> </ul>





 (Partial Color)	<p>Surrounds a chosen point in monochrome to signalize a subject.</p>  <ol style="list-style-type: none"><li>① Touch the center point of the desired image to retouch, then touch .</li><li>② Adjust the desired range to retouch with , then touch .</li><li>③ Touch [OK].</li></ol>
--	---

 (Multi-Purpose Resize): Changing the image size according to usage

You can change the aspect ratio and size of the shooting images, then record them as the new files.

You can convert images to the 16:9 aspect ratio for high definition viewing and to the VGA size for blog or e-mail attachments.

HDTV (  )	Changes the aspect ratio from 4:3/3:2 to 16:9 and saves as 2M size. 
Blog/E-mail (  )	Changes the aspect ratio from 16:9/3:2 to 4:3 and saves as VGA size. 

- ① Display the desired image to be changed.
- ② Touch [MENU], and then touch  (Multi-Purpose Resize).
- ③ Touch the desired size of the image ( (HDTV) or  (Blog/E-mail)).
- ④ Specify the area you want to trim and touch .
- ⑤ Touch [Save].

- For details about the image size, see page 12.
- You cannot resize movies.
- You cannot resize the images from VGA to  (HDTV).
- If you enlarge and resize the image using [Multi-Purpose Resize], the image quality may deteriorate.

** (Wide Zoom Display): Displaying still images in 16:9**

During playback, still images at a 4:3 and 3:2 aspect ratio are played at a 16:9 aspect ratio. In this case the top and bottom of the image will be slightly cropped.





Touching the center of the touch panel changes to the wide zoom exit screen.

- Turning off the power or switching to shooting mode cancels this setting.
- The only images that can be played in Wide Zoom are 4:3 and 3:2 images. Movies, 16:9 images, and portrait images cannot be zoomed.

** (Slideshow): Playing back images in succession along with effects and music**

This item has the same function as  (Slideshow) button in playback mode. You can change the slideshow settings.

- ① Touch [MENU] →  (Slideshow) →  (Slideshow).
- ② Touch the desired menu item.
- ③ Touch the desired setting, then touch [Start].

The following items can be set.  
The default settings are marked with .

Playback Range		
This setting is fixed to [Folder] if a "Memory Stick Duo" (not supplied) is not inserted.		
	Folder	Plays back all the images in the selected folder.
	All	Plays back all the images in order.

Playback Image		
	Movies/Still images	Plays back the movies and still images in order.
	Movies Only	Plays back only movies in order.
	Still images Only	Plays back only still images in order.

Effects		
<input checked="" type="checkbox"/>	Simple	A simple slideshow suitable for a wide range of scenes.
<input type="checkbox"/>	Nostalgic	A moody slideshow reproducing the atmosphere of a movie scene.
<input type="checkbox"/>	Stylish	A stylish slideshow proceeding at a middle tempo.
<input type="checkbox"/>	Active	A high-tempo slideshow suitable for active scenes.
<input type="checkbox"/>	Normal	A basic slideshow switching images at a predetermined interval.

- When [Simple], [Nostalgic], [Stylish], or [Active] have been set, in the case of movies, beginning sections of movies are displayed.
- Music is not played (set to [Off]) during a [Normal] slideshow. The sound of movie files will be heard.

Music		
The preset-Music differs depending on the effect you select. The background music and effect combination can be changed. It is also possible to choose from multiple background music (BGM) selections.		
<input type="checkbox"/>	Off	Does not use BGM.
<input checked="" type="checkbox"/>	Music1	The default setting for a [Simple] slideshow.
<input type="checkbox"/>	Music2	The default setting for a [Nostalgic] slideshow.
<input type="checkbox"/>	Music3	The default setting for a [Stylish] slideshow.
<input type="checkbox"/>	Music4	The default setting for a [Active] slideshow.



- If you select [Music1] – [Music4], the camera does not play back the sound of movie files.

Interval		
<input type="checkbox"/>	3 sec	Sets the display interval of images for a [Normal] slideshow.
<input type="checkbox"/>	5 sec	
<input type="checkbox"/>	10 sec	
<input type="checkbox"/>	30 sec	
<input type="checkbox"/>	1 min	
<input checked="" type="checkbox"/>	Auto	The interval is set to suit the selected [Effects] item. The setting is fixed to [Auto] when [Normal] is not selected as the [Effects].

- The [Interval] setting is invalid during movie playback.

Repeat		
	On	Plays back images in a continuous loop.
	Off	After all the images have been played back, the slideshow ends.



### To add /change Music files

You can transfer a desired music file from your CDs or MP3 files to the camera to play back during slideshow. You can transfer music using [ Music Tool] in [ (Printing, Other)] on the HOME screen and the “Music Transfer” software (supplied) installed on a computer. For details, see pages 101 and 103.



- You can record up to four pieces of music on the camera (The four preset pieces (Music1 – Music4) can be replaced with the ones you transferred).
- The maximum length of each music file for music playback of the camera is about 5 minutes.
- If you cannot play back a music file due to damage or other malfunctions to the file, execute [Format Music] (page 101) and transfer the music again.

## (Delete): Deleting images

Selects and deletes images in single-image mode or in index mode.

 (This Image)	Deletes the image that is now selected. • This item appears only in single-image mode.
 (Multiple Images)	Selects and deletes multiple images.
 (All In This Folder)	Deletes all images in the selected folder.



### To delete an image

- ① Display the image you want to delete.
- ② Touch [MENU] to display the menu.
- ③ Display  (Delete) by touching , then touch it.
- ④ Touch  (This Image).
- ⑤ Touch [OK].



### To select and delete multiple images

- ① Touch [MENU] in single-image mode or in index mode.
- ② Display  (Delete) by touching , then touch it.
- ③ Touch  (Multiple Images).

In single-image mode:

- ④ Use  to display the image you want to delete, then touch the center of that image.  
The  mark is attached to the selected image.





- ⑤ Touch  to display other image you want to delete, then touch the center of that image.  
To cancel the deletion, touch the image again to deselect the mark.
- ⑥ Touch  → [OK].

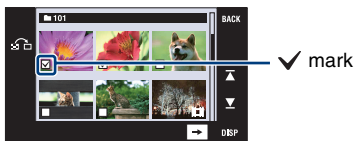

In index mode:

- ④ Touch the thumbnail image you want to delete.  
The  mark is attached to the selected image.



- ⑤ To delete other images, repeat step ④.
  - ⑥ Touch  → [OK].
- Touch  on the index screen to return to the single-image screen.





### To delete all images in the folder

- ① Touch [MENU] in index mode.
- ② Display  (Delete) by touching , then touch it.
- ③ Touch  (All In This Folder).
- ④ Touch [OK].



## (Protect): Preventing accidental erasure

Protects images against accidental erasure.

 (Protect) indicator appears on the protected image.



 (This Image)	Protects/unlocks the currently selected image. • This item appears only in single-image mode.
 (Multiple Images)	Selects and protects/unlocks multiple images.
 ON (Select All in This Folder)	Protects all images in the selected folder. • This item appears only in index mode.
 OFF (Clear All in This Folder)	Unlocks all images in the selected folder. • This item appears only in index mode.

### To protect an image







- ① Display the image you want to protect.
- ② Touch [MENU] to display the menu.
- ③ Display  (Protect) by touching ▲/▼, then touch it.
- ④ Touch  (This Image).







### To select and protect multiple images

- ① Touch [MENU] in single-image mode or in index mode.
- ② Display  (Protect) by touching ▲/▼, then touch it.
- ③ Touch  (Multiple Images).





In single-image mode:

- ④ Use   to display the image to be protected, then touch the center of that image.  
The  mark is attached to the selected image.
- ⑤ Touch   to display other images you want to protect, then touch the center of that image.
- ⑥ Touch  → [OK].

In index mode:

- ④ Touch the thumbnail image of the image you want to protect.  
The  mark is attached to the selected image.
  - ⑤ To protect other images, repeat step ④.
  - ⑥ Touch  → [OK].
- Touch   on the index screen to return to the single-image screen.

### To select all images in the folder

- ① Touch [MENU] in index mode.
  - ② Display  (Protect) by touching /, then touch it.
  - ③ Touch  (Select All in This Folder).
  - ④ Touch [OK].
- You cannot protect all the images when there are more than 100 files.
  - Note that the formatting erases all the data even if the images are protected, and these images cannot be restored.
  - It may take some time to protect an image.

### To cancel the protection

Touch the image whose protection you want to cancel by taking the same steps as in “To select and protect multiple images”.

The  (Protect) indicator disappears.

- Protection can be removed for all images in a selected folder by touching  (Clear All in This Folder).

## DPOF: Adding a Print order mark



Adds a print order mark (DPOF) to the image you want to print.  
See page 109.

## (Print): Printing images using a printer

Prints the recorded images.  
See page 106.

 (Rotate): Rotating a still image

Rotates a still image.

- ① Display the image to be rotated.
- ② Touch [MENU] to display the menu.
- ③ Display  (Rotate) by touching ▲/▼, then touch it.
- ④ Touch [ ] to rotate the image.
- ⑤ Touch [OK].

- You cannot rotate protected images or movies.
- You may not be able to rotate images shot with other cameras.
- When viewing images on a computer, the image rotation information may not be reflected depending on the software.

 (Select Folder): Selecting the folder for viewing images

Selects the folder containing the image you want to play back.

- ① Select the desired folder with ▲/▼.

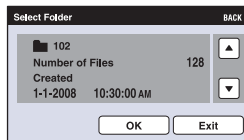

- ② Touch [OK].

**To cancel selecting the folder**

Touch [Exit] or [BACK] in step ②.

 On the folders

The camera stores images in a specified folder of a “Memory Stick Duo”. You can change the folder or create a new one.

- To create a new folder → [Create REC.Folder] (page 70).
- To change the folder for recording images → [Change REC.Folder] (page 71).
- When multiple folders are created in the “Memory Stick Duo” and the first or last image in the folder is displayed, the following indicators appear.

: Moves to the previous folder



: Moves to the next folder

: Moves to either the previous or next folders

## (Volume Settings): Adjusting the volume

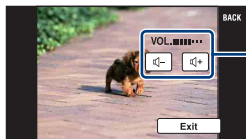
Adjusts the volume for slideshow and movie playback.



Adjust the volume by touching / .

- You can adjust the volume during movie and slideshow playback (pages 31, 33).



# Customizing the Manage Memory feature and the Settings

You can change the default settings using  (Manage Memory) or  (Settings) on the HOME screen.

## 1 Touch [HOME] to display the HOME screen.

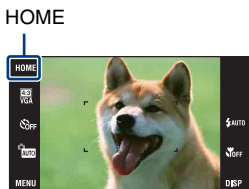

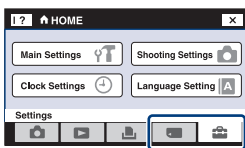

## 2 Touch (Manage Memory) or (Settings).



## 3 Touch the desired setting item.

## 4 Touch the setting item that you want to change, and then touch the desired setting value.

When you select  (Settings), touch / on the right of the screen to display the other setting items.

## 5 Touch [OK].

### To cancel the setting change

Touch [Cancel] if it is shown as an option on the screen.  
If not, touch [BACK] or [X].

- This setting is maintained even when the power is turned off.

## Memory Tool — Memory Stick Tool

This item appears only when a “Memory Stick Duo” is inserted in the camera.

### Format

Formats the “Memory Stick Duo”. A commercially available “Memory Stick Duo” is already formatted, and can be used immediately.

- Note that formatting permanently erases all data on a “Memory Stick Duo”, including even protected images.

- ① Touch [Format].  
The message “All data on Memory Stick will be erased” appears.
- ② Touch [OK].  
Formatting starts.

### To cancel formatting

Touch [Cancel] or [BACK] in step ②.

### Create REC.Folder

Creates a folder in a “Memory Stick Duo” for recording images.

- ① Touch [Create REC.Folder].  
The message “Creating REC. folder” appears.

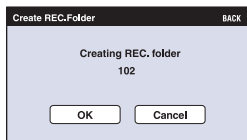

- ② Touch [OK].  
A new folder is created with a number incremented one higher than the largest number, and the folder becomes the current recording folder.

### To cancel the folder creation

Touch [Cancel] or [BACK] in step ②.

- When not creating a new folder, the “101” folder is selected as the recording folder.
- You can create folders designated up to “999”.
- You cannot delete a folder with the camera. To delete a folder, use your computer, etc.
- Images are recorded in the newly created folder until you create another folder or select another recording folder.
- Up to 4,000 images can be stored in one folder. When the folder capacity is exceeded, a new folder is automatically created.
- For details, see “Image file storage destinations and file names” (page 97).

## Change REC.Folder

Changes the folder currently used for recording images.

- ① Touch [Change REC.Folder].  
The folder selection screen appears.

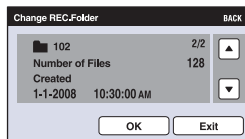

- ② Touch [OK].

### To cancel changing the recording folder

Touch [Exit] or [BACK] in step ②.

- You cannot select the “100” folder as a recording folder.
- You cannot move recorded images to another folder.

## Copy

Copies all images in the internal memory to a “Memory Stick Duo”.

- ① Insert a “Memory Stick Duo” having sufficient free capacity.
- ② Touch [Copy].  
The message “All data on internal memory will be copied” appears.
- ③ Touch [OK].  
Copying starts.

### To cancel copying

Touch [Cancel] or [BACK] in step ③.

- Use a fully charged battery pack. If you attempt to copy image files using a battery pack with little remaining charge, the battery pack may run out, causing copying to fail or possibly corrupting the data.
- You cannot select images to copy.
- The original images in the internal memory are retained even after copying. To delete the contents of the internal memory, remove the “Memory Stick Duo” after copying, then format the internal memory ([Format] in [Internal Memory Tool]) (page 73).
- A new folder is created on the “Memory Stick Duo” and all the data will be copied to it. You cannot choose a specific folder and copy images to it.
- The **DPOF** (Print order) marks on the images are not copied.



## Memory Tool — Internal Memory Tool

This item does not appear when a “Memory Stick Duo” is inserted in the camera.

### Format

Formats the internal memory.

- Note that formatting permanently erases all data in the internal memory, including even protected images.

- ① Touch [Format].  
The message “All data on internal memory will be erased” appears.
- ② Touch [OK].  
Formatting starts.

### To cancel formatting

Touch [Cancel] or [BACK] in step ②.

## Main Settings — Main Settings 1

The default settings are marked with .

### Beep

Selects the sound produced when you operate the camera.

	Shutter	Turns on the shutter sound when you press the shutter button.
	On	Turns on the beep/shutter sound when you operate the touch panel/press the shutter button.
	Off	Turns off the beep/shutter sound.

### Function Guide

When you operate the camera, the function guide appears.

	On	Displays the function guide.
	Off	Does not display the function guide.

- The guide is displayed during playback even if this is set to [Off].

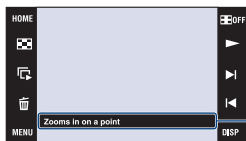

The display of this guide can be turned on and off with the above setting.

- The guide that is displayed by touching [?] cannot be turned on or off with the above setting. To turn off this guide, touch [?] again (page 21).

### Continuous Play

Selects whether to play back all movies or still images successively in single-image mode. For details, see page 33.

	On	Displays the continuous playback button.
	Off	Does not display the continuous playback button.

## Initialize

Initializes the setting to the default setting. Even if you execute this function, the images stored in the internal memory are retained.

- ① Touch [Initialize].  
The message “Reset to default settings” appears.
- ② Touch [OK].  
The settings are reset to the default setting.

### To cancel initializing

Touch [Cancel] or [BACK] in step ②.

- Be sure not to power off the camera while initializing.

## Calibration

Enables you to perform calibration when the touch panel buttons do not react at the appropriate points where you touch.

Touch the “X” mark displayed on the screen with the corner of a “Memory Stick Duo” or the like.

To stop the calibration process mid-way, touch [Cancel]. The adjustments made up to that point are not effected.

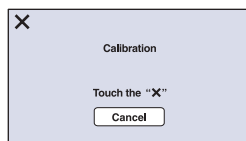

The X mark moves on the screen.

If you fail to touch the right spot, the calibration is not performed. Touch the X mark again.

## Main Settings — Main Settings 2

The default settings are marked with .

### USB Connect

Selects the USB mode when connecting the camera to a computer or a PictBridge compliant printer using the USB cable.

	PictBridge	Connects the camera to a PictBridge compliant printer (page 106).
	Mass Storage	Establishes a Mass Storage connection between the camera and a computer or other USB device (page 94).
	Auto	<p>The camera recognizes automatically and sets up communication with a computer or PictBridge compliant printer (pages 94 and 106).</p> <ul style="list-style-type: none"> <li>• If you cannot connect the camera to a PictBridge compliant printer with the [Auto] setting, select [PictBridge].</li> <li>• If you cannot connect the camera to a computer or a USB device with the [Auto] setting, select [Mass Storage].</li> </ul>

### CTRL FOR HDMI

This setting allows (TV) remote-control of a camera that is connected to a “BRAVIA” Sync TV using an HDMI cable (not supplied). For details on “BRAVIA” Sync, see page 87.

	On	Allows remote-controlled operation.
	Off	Disallows remote-controlled operation.

- You can do the playback operation with the remote controller of your TV by connecting your camera to a “BRAVIA” Sync compatible TV launched in 2008 or later with the HDMI cable.





## Video Out

Sets the video signal output according to the TV color system of the connected video equipment. The TV color systems differ depending on the country and region. To view images on a TV screen, check the TV color system of the country or region of use (page 88).

NTSC	Sets the video output signal to NTSC mode (e.g., for the USA, Japan).
PAL	Sets the video output signal to PAL mode (e.g., for Europe).

## TV TYPE

Set to the aspect ratio of television to be connected for playback.

<input checked="" type="checkbox"/>	16:9	<p>Selects this item to play back the images on a wide screen television.</p> <p>16:9 image                      4:3 image</p> <div style="display: flex; justify-content: space-around;">   </div>
	4:3	<p>Selects this item to play back the images on a 4:3 ratio television.</p> <p>16:9 image                      4:3 image</p> <div style="display: flex; justify-content: space-around;">   </div>





## Shooting Settings — Shooting Settings 1

The default settings are marked with .

### AF Illuminator



The AF illuminator supplies fill light to focus more easily on a subject in dark surroundings. The AF illuminator emits red light allowing the camera to focus easily when the shutter button is pressed halfway, until the focus is locked. The  $\text{AF-ON}$  indicator appears at this time.

	Auto	Uses the AF illuminator.
	Off	Does not use AF illuminator.

- If the AF illuminator light does not reach the subject sufficiently or the subject has no contrast, focus will not be achieved.
- Focus is achieved as long as the AF illuminator light reaches the subject, regardless of whether light fails to reach the center of the subject.
- You cannot use the AF illuminator when:
  - Focus preset is set (page 45).
  -  (Twilight) mode,  (Landscape) mode,  (Fireworks) mode or  (Hi-Speed Shutter) mode is selected in the Scene Selection mode.
- When you use AF illuminator, the normal AF range finder frame is disabled and a new AF range finder frame is displayed by a dotted line. AF operates with priority on subjects located near the center of the frame.
- The AF illuminator emits very bright light. Although there is no health hazard, do not look directly into the AF illuminator emitter at close range.

### Grid Line

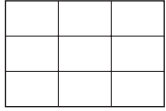
With reference to the grid lines, you can easily set a subject in a horizontal/vertical position.

	On	Displays the grid lines. 
	Off	Does not display the grid lines.

- The grid lines are not recorded.

## AF Mode

Selects the auto focus operation mode.

<input checked="" type="checkbox"/>	Single	Automatically adjusts the focus when you press and hold the shutter button halfway down. This mode is useful for shooting stationary subjects.
	Monitor	Automatically adjusts the focus before you press and hold the shutter button halfway down. This mode shortens the time needed for focusing. <ul style="list-style-type: none"> <li>• Battery consumption is faster than in [Single] mode.</li> </ul>

- AF mode setting is invalid when the Face Detection function is activated.

## Digital Zoom

Selects the digital zoom mode. The camera enlarges the image using optical zoom (up to 5 $\times$ ). When the zoom scale is exceeded, the camera uses either smart or precision digital zoom.

<input checked="" type="checkbox"/>	Smart (Smart zoom) (sQ)	Enlarges the image digitally within the range where the image will not be distorted, according to the image size. This is not available when the image size is set to [10M], [3:2(8M)] or [16:9(7M)]. <ul style="list-style-type: none"> <li>• The total zoom scale of Smart zoom is shown in the following table.</li> </ul>
	Precision (Precision digital zoom) (PQ)	Enlarges all image sizes by the total zoom scale of approximately 10 $\times$ , including the optical zoom 5 $\times$ . However, note that the picture quality deteriorates when the optical zoom scale is exceeded.
	Off	Does not use the digital zoom.

### Image size and total zoom scale using Smart zoom (including optical zoom 5 $\times$ )

Size	Total zoom scale
5M	Approx. 7.0 $\times$
3M	Approx. 8.9 $\times$
VGA	Approx. 28 $\times$
16:9(2M)	Approx. 9.5 $\times$

## Shooting Settings — Shooting Settings 2

The default settings are marked with .

### Auto Orientation

When the camera is rotated to shoot a portrait (vertical) image, the camera records its position change and displays the image in the portrait position.

<input checked="" type="checkbox"/>	On	Records the image with the correct orientation.
<input type="checkbox"/>	Off	Does not use Auto Orientation.

- Black is displayed to the left and right of vertical orientation images.
- Depending on the shooting angle of the camera, the orientation of the image may not be recorded correctly. If an image is not recorded in the correct orientation, you can rotate the image, following the procedure on page 67.

### Auto Review

Displays the recorded image on the screen for approximately two seconds immediately after shooting a still image.



<input checked="" type="checkbox"/>	On	Uses the Auto Review.
<input type="checkbox"/>	Off	Does not use Auto Review.

- If you press the shutter button halfway down, the recorded image display disappears and you can immediately shoot the next image.

## Clock Settings

### Clock Settings

Sets the date and time.

- ① Select [ Clock Settings] from  (Settings) on the HOME screen.
- ② Touch [Clock Settings].
- ③ Touch the desired date display format, then touch .  
The clock settings screen appears.

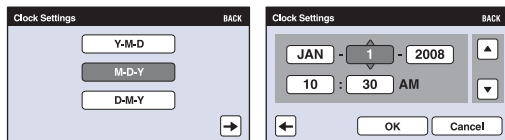

- ④ Touch each item, then set its numeric value by touching ▲/▼.
  - ⑤ Touch [OK].
- Midnight is indicated as 12:00 AM, and noon as 12:00 PM.

### To cancel the clock setting

Touch [Cancel] or [BACK] in step ⑤.

---

## **A** Language Setting

### Language Setting

Selects the language to be used in the menu items, warnings and messages.



# Viewing images on a TV

You can view images on a TV by connecting the camera to a TV. The connection varies according to the type of TV the camera is connected to. See “TV TYPE” (page 77).

## Viewing images by connecting the camera to a TV with the supplied AV cable

Turn off both the camera and the TV before connecting the camera to the TV.

- 1 Connect the A/V OUT jack of the multi-output stand (supplied) and the audio/video input jacks of the TV with the AV cable (supplied), then attach the camera on the multi-output stand.**

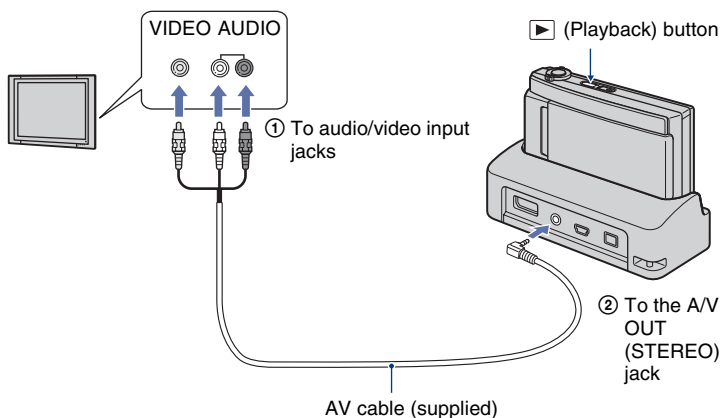

- 2 Turn on the TV and set the input.**

- Refer also to the operating instructions supplied with the TV.

- 3 Press ▶ (Playback) button to turn on the camera.**

Images shot with the camera appear on the TV.

Touch ◀/▶ on the LCD screen of the camera to select the desired image.

- For details on the operation of this camera, see page 86.

- When using the camera abroad, it may be necessary to switch the video signal output to match that of your TV system (page 77).

### Viewing an image by connecting the camera to an HD TV

When using an HD (High Definition) TV with an HDMI jack, connecting the camera to the TV with an HDMI cable (not supplied) allows you to enjoy images shot with the camera at high picture quality\*.

\* Images shot in [VGA] image size cannot be played back in HD format.

- With [Multi-Purpose Resize], the aspect ratio can be converted to 16:9 for High Definition viewing (page 60).

Turn off both the camera and the TV before connecting the camera to the TV.

#### 1 Connect the multi-output stand (supplied) to an HD (High Definition) TV, then attach the camera on the multi-output stand.

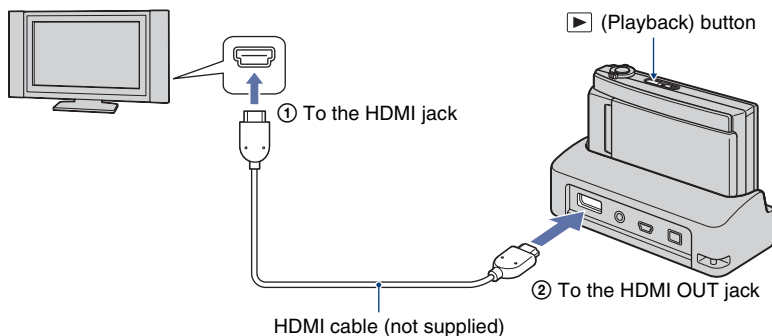

#### 2 Turn on the TV and set the input.

- Refer also to the operating instructions supplied with the TV.

#### 3 Press ▶ (Playback) button to turn on the camera.

Images shot with the camera appear on the TV.

Touch ◀/▶ on the LCD screen of the camera to select the desired image.

- For details on the operation of this camera, see page 86.

- When using the camera abroad, it may be necessary to switch the video signal output to match that of your TV system (page 77).
- Output to the TV is not possible while recording a movie.
- Use an HDMI cable with the HDMI logo.
- Some devices may not work properly.
- Do not connect the device output terminal to the multi-output stand output terminal. The images and sounds will not be output. Also, this may cause a malfunction.

### On “PhotoTV HD”

This camera is compatible with the “PhotoTV HD” standard.

By connecting Sony’s PhotoTV HD-compatible devices using an HDMI cable (not supplied), whole new world of photos can be comfortably enjoyed in breathtaking Full HD quality. PhotoTV HD allows for a highly-detailed, photo-like expression of subtle textures and colors.

- When this camera is connected to a Sony TV that supports VIDEO-A Mode, the TV will automatically be set to the picture quality best suited for still images. For details, see the operating instruction for supported TVs.

### Controlling the camera while outputting to a TV

When the camera is connected to a TV using AV cables or an HDMI cable, the items that can be controlled are limited.

Control operations by touching the buttons displayed on the LCD screen of the camera.

- If you are using a TV that supports "BRAVIA" Sync, [6] and [7] can be controlled using the remote controller supplied with the TV.

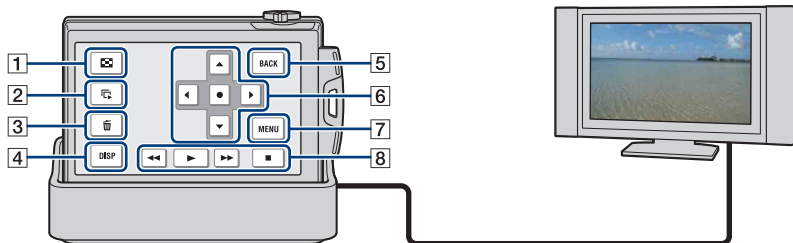

[1] Image Index

[2] Slideshow

[3] Delete

[4] Display Setup

[5] BACK

[6] Control buttons

[7] MENU

[8] Movie operation buttons

(Fast rewind/Playback/Fast forward/Stop)

## Operating the MENU items

Detailed settings can be made from the menu for the functions listed below.

- Slideshow
- Playback Zoom
- Delete
- Rotate
- Single Image
- Image Index(6-up)
- Image Index(20-up)

① Touch [MENU] on the LCD screen.

The menu items appear on the TV screen.

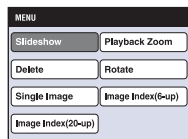

- ② Touch ◀/▶/▼/▲ (control buttons) on the camera's LCD screen, then select the desired setting.
- ③ Touch ● (middle button).

## Using "BRAVIA" Sync

When connecting to a TV that supports "BRAVIA" Sync\* using an HDMI cable, you can operate the playback functions of the camera with the TV remote controller.

- ① Connect the HDMI OUT jack of the multi-output stand and the HDMI jack of the TV using an HDMI cable.
- ② Attach the camera on the multi-output stand.
- ③ Turn on the camera.
- ④ Operate the camera with the TV remote controller.

\* You can do the playback operation with the remote controller of your TV by connecting your camera to a "BRAVIA" Sync compatible TV launched in 2008 or later with the HDMI cable. For details, see the operating instructions supplied with the TV.

- The following operations can be performed using the remote controller.
  - Images can be advanced using the left/right keys on the TV's remote controller.
  - The TV's power automatically turns on when the camera's power is turned on. The video input of the TV is also automatically switched so that it connects to the camera.
  - After enjoying your images, the camera's power automatically turns off when the TV's power is turned off.
  - Pressing SYNC MENU on the TV's remote controller displays the menu screen, where various associated operations can be performed.

If the camera functions in an undesired manner when controlling with the TV's remote controller, such as when connected via HDMI to another manufacturer's TV, set the item [CTRL FOR HDMI] found under  (Settings) on the HOME screen to [Off] (page 76).

### **On TV color systems**

If you want to view images on a TV screen, you need a TV with a video input jack and the AV cable. The color system of the TV must match that of the digital still camera. Check the following lists for the TV color system of the country or region where the camera is used.

#### **NTSC system**

Bahama Islands, Bolivia, Canada, Central America, Chile, Colombia, Ecuador, Jamaica, Japan, Korea, Mexico, Peru, Surinam, Taiwan, the Philippines, the U.S.A., Venezuela, etc.

#### **PAL system**

Australia, Austria, Belgium, China, Czech Republic, Denmark, Finland, Germany, Holland, Hong Kong, Hungary, Italy, Kuwait, Malaysia, New Zealand, Norway, Poland, Portugal, Singapore, Slovak Republic, Spain, Sweden, Switzerland, Thailand, United Kingdom, etc.

#### **PAL-M system**

Brazil

#### **PAL-N system**

Argentina, Paraguay, Uruguay

#### **SECAM system**

Bulgaria, France, Guiana, Iran, Iraq, Monaco, Russia, Ukraine, etc.



For details on using a Macintosh computer, refer to “Using your Macintosh computer” (page 102). Illustrations of screens used in this section are based on the English version.



## Install the software (supplied) first (page 91)



- Installing the software as follows:
  - “Picture Motion Browser”
  - “Music Transfer”

## Copying images to your computer (page 94)

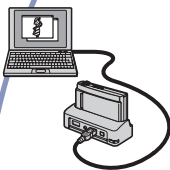

- Copying images to your computer using “Picture Motion Browser”.
- Enjoying images using “Picture Motion Browser” and “Music Transfer” as follows:
  - Viewing images saved on your computer
  - Editing images
  - Displaying the shooting locations of still images on maps online
  - Creating a disc with the images shot (requires CD or DVD disc writing drive)
  - Printing or saving still images with the date
  - Adding/changing Music for slideshow (using “Music Transfer”)

Additional information on this product and answers to frequently asked questions can be found at the Sony Customer Support Website.  
<http://www.sony.net/>

## Recommended computer environment

The following environment is recommended for a computer connected to the camera.

### Recommended environment for copying images

**OS (pre-installed):** Microsoft Windows 2000 Professional SP4, Windows XP\* SP3/Windows Vista SP1\*

- Operation is not assured in an environment based on an upgrade of the operating systems described above or in a multi-boot environment.

**USB jack:** Provided as standard

### Recommended environment for using “Picture Motion Browser” and “Music Transfer”

**OS (pre-installed):** Microsoft Windows 2000 Professional SP4, Windows XP\* SP3/Windows Vista SP1\*

**CPU:** Intel Pentium III 800 MHz or faster (When playing/editing High Definition movies: Intel Pentium 4 2.8 GHz or faster, Intel Pentium D 2.8 GHz or faster, Intel Core Duo 1.66 GHz or faster, Intel Core 2 Duo 1.20 GHz or faster)

**Memory:** 512 MB or more (When playing/editing High Definition movies: 1 GB or more)

**Hard Disk:** Disk space required for installation—approximately 400 MB

**Display:** Screen resolution: 1,024 × 768 dots or more

\* 64-bit editions and Starter (Edition) are not supported.

## Note on playback of movie files (MPEG-4 AVC/H.264)

To play back and editing movie files (MPEG-4 AVC/H.264) recorded by the camera, you need to install the software compatible with MPEG-4 AVC/H.264 or “Picture Motion Browser” on your computer.

- Even under a PC environment where operations are guaranteed, sometimes images cannot be played back smoothly due to dropped frames. Note that the transferred image itself is not affected.
- If you are using a notebook PC, be sure to use the PC with the AC adaptor plugged in. Sometimes normal operations are not possible due to the power savings function of the PC.

## Notes on connecting the camera to a computer

- The computer environment must also satisfy the operating requirements of the OS.
- Operations are not guaranteed under some PC environments. For example, operations may be adversely affected by other software running in the background.
- If you connect two or more USB devices to a single computer at the same time, some devices, including the camera, may not operate, depending on the types of USB devices you are using.
- Operations are not guaranteed when using a USB hub.
- Connecting the camera using a USB interface that is compatible with Hi-Speed USB (USB 2.0 compliant) allows advanced transfer (high speed transfer) as the camera is compatible with Hi-Speed USB (USB 2.0 compliant).
- There are three modes for a USB connection when connecting a computer, [Auto] (default setting), [Mass Storage] and [PictBridge] modes. This section describes the [Auto] and [Mass Storage] as examples. For details on [PictBridge], see page 76.
- When your computer resumes from a suspend or sleep mode, communication between the camera and your computer may not recover at the same time.

# Installing the software (supplied)

You can install the software (supplied) using the following procedure.

- Log on as Administrator.

---

## 1 Turn on your computer, and insert the CD-ROM (supplied) into the CD-ROM drive.

The installation menu screen appears.



- If it does not appear, double-click [Computer] (in Windows XP/2000, [My Computer]) →  (SONYPICUTUTIL).
- The AutoPlay screen may appear. Select “Run Install.exe.” and follow the instructions that appear on the screen to proceed with the installation.

---

## 2 Click [Install].

The “Choose Setup Language” screen appears.

---

## 3 Select the desired language, then click [Next].

The “License Agreement” screen appears.

---

## 4 Read the agreement carefully. If you accept the terms of the agreement, click the radio button next to [I accept the terms of the license agreement] and then click [Next].

---

## 5 Follow the instructions on the screen to complete the installation.

- When the restarting confirmation message appears, restart the computer following the instructions on the screen.
- DirectX may be installed depending on the system environment of your computer.



---

## 6 Remove the CD-ROM after the installation is complete.

- Installing software as follows:
  - Picture Motion Browser
  - Music Transfer

## Installing the software (supplied)

After you install the software, the short cut icons for “Picture Motion Browser”, “PMB Guide”, “Music Transfer” are created on the desktop.

 <p>PMB – Picture Motion Browser</p>	Double-click to start “Picture Motion Browser”.
 <p>PMB Guide</p>	Double-click to start “PMB Guide”.
 <p>Music Transfer</p>	Double-click to start “Music Transfer”.

# On the “Picture Motion Browser” (supplied)

You can use still images and movies from the camera more than ever by taking advantage of the software.

This section summarizes the “Picture Motion Browser”.

## “Picture Motion Browser” overview

With the “Picture Motion Browser”:

- You can import images shot with the camera and display them on the computer.
- You can organize images on the computer on a calendar by shooting date to view them.
- You can copy images on a PC to the “Memory Stick Duo” so they can be viewed on this camera.
- You can retouch (Red Eye Correction, etc.), print, and send still images as e-mail attachments, change the shooting date and more.
- You can edit the movies.
- You can print or save the still images with the date.
- You can create a data disc using a CD burner drive or DVD burner drive.
- You can upload the image to the Web.

For details, refer to “PMB Guide”.

## Starting the “PMB Guide”

Double-click the  (PMB Guide) icon on the desktop.

To access “PMB Guide” from the Start menu, click [Start] → [All Programs] (in Windows 2000, [Programs]) → [Sony Picture Utility] → [Help] → [PMB Guide].

## Starting and exiting the “Picture Motion Browser”

### Starting the “Picture Motion Browser”

Double-click the  (Picture Motion Browser) icon on the desktop.

Or, from the Start menu: Click [Start] → [All Programs] (in Windows 2000, [Programs]) → [Sony Picture Utility] → [PMB – Picture Motion Browser].

- The confirmation message of the Information tool appears on the screen when starting the “Picture Motion Browser” for the first time. Select [Start]. This function informs you of news, such as software updates. You can change the setting later.

### Exiting the “Picture Motion Browser”

Click  button on the top right corner of the screen.

# Copying images to your computer using the “Picture Motion Browser”

## Preparing the camera and the computer

**1** Insert a “Memory Stick Duo” with recorded images into the camera.

- When copying images in the internal memory, this step is unnecessary.

**2** Insert the sufficiently charged battery pack into the camera, or connect the multi-output stand to a wall outlet (wall socket) with the AC Adaptor (not supplied).

- When you copy images to your computer using a battery pack with little remaining charge, copying may fail or image data may become corrupted if the battery pack shuts down too soon.

**3** Attach the camera on the multi-output stand.

**4** Turn on the computer, then press the  (Playback) button of the camera.

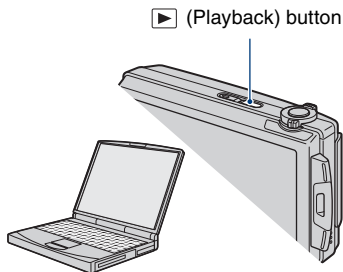

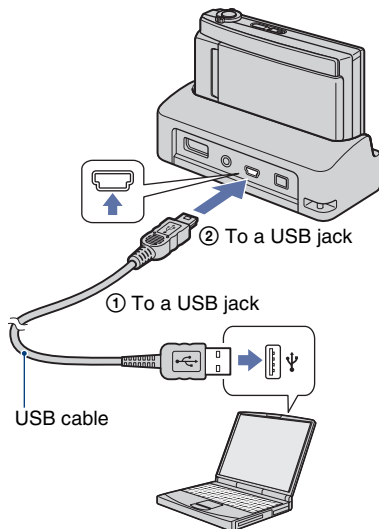

## Connecting the camera to your computer

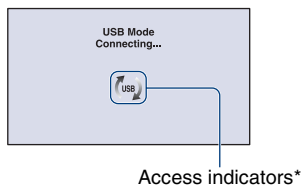

“Connecting...” appears on the screen of the camera.



When a USB connection is established for the first time, your computer automatically runs a program to recognize the camera. Wait for a while.

- \*  is displayed on the screen during the communication session. Do not operate the computer while the indicator is displayed. When the indicator changes to , you can start using the computer again.
- If “Mass Storage” does not appear, set [USB Connect] to [Mass Storage] (page 76).

### Copying images to a computer

## 1 Connect the camera to a computer as described in “Connecting the camera to your computer”.

After making a USB connection, the [Import Media Files] screen of “Picture Motion Browser” appears automatically.

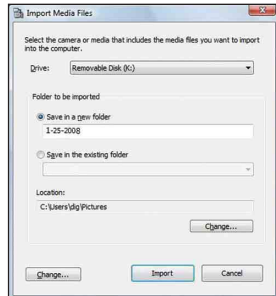

- If you use the Memory Stick slot, refer to page 98.
- If the AutoPlay Wizard appears, close it.

## 2 Import the images.

To start importing images, click the [Import] button.

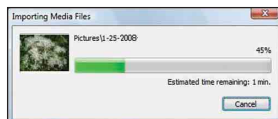

By default, images are imported into a folder created in “Pictures” (in Windows XP/2000, “My Pictures”) that is named with the date of importing.

- For details on the “Picture Motion Browser”, refer to “PMB Guide”.

### Viewing images on your computer

When importing is complete, the “Picture Motion Browser” starts. Thumbnails of the imported images are displayed.



- The “Pictures” (in Windows XP/2000, “My Pictures”) folder is set as the default folder in “Viewed folders”.

Organize images on the computer on a calendar by shooting date to view them. For details, see the “PMB Guide”.

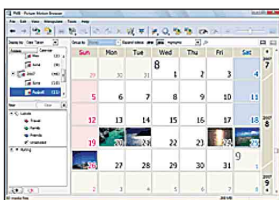

Example: Month display screen

### To delete the USB connection

Perform the procedures from step ① to ④ below before:

- Disconnecting the USB cable.
- Removing a “Memory Stick Duo”.
- Inserting a “Memory Stick Duo” into the camera after copying images from the internal memory.
- Turning off the camera.

- ① Double-click the disconnect icon on the taskbar.

Windows Vista



Double-click here

Windows XP/Windows 2000



Double-click here

- ② Click  (USB Mass Storage Device) → [Stop].
- ③ Confirm the device on the confirmation window, then click [OK].
- ④ Click [OK].  
The device is disconnected.
  - Step ④ is unnecessary for Windows Vista/XP.

## Image file storage destinations and file names

The image files recorded with the camera are grouped as folders on the “Memory Stick Duo” or the internal memory.

### Example: viewing folders on Windows Vista

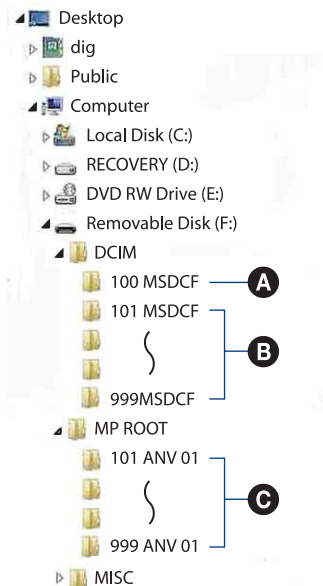

**A** Folder containing image data recorded using a camera not equipped with the folder creating function.

**B** Folder containing image data recorded using the camera.  
When no new folders are created, there are folders as follows:

- “Memory Stick Duo”: 101MSDCF
- Internal memory: 101\_SONY

**C** Folder containing movie data recorded using the camera.  
When no new folders are created, there are folders as follows:

- “Memory Stick Duo”: 101ANV01
- Internal memory: 101ANV01

- You cannot record any images to the “100MSDCF” or “100ANV01” folders. The images in these folders are available only for viewing.

- You cannot record/play back any images to the “MISC” folder.

- Image files are named as follows:

- Still image files: DSC0□□□□.JPG

- Movie files

- 720p: MAH0□□□□.MP4

- VGA: MAQ0□□□□.MP4

- Index image files that are recorded when you record movies

- 720p: MAH0□□□□.THM

- VGA: MAQ0□□□□.THM

□□□□ stands for any number within the

range from 0001 to 9999. The numerical portions of the name of a movie file recorded in movie mode and its corresponding index image file are the same.

- For more information about folders, see pages 67 and 70.

# Copying images to your computer without “Picture Motion Browser”

You can copy images to your computer without “Picture Motion Browser” as follows.

## For a computer with a Memory Stick slot:

Remove the “Memory Stick Duo” from the camera and insert it in the Memory Stick Duo Adaptor. Insert the Memory Stick Duo Adaptor in the computer and copy the images.

- Even when you are using Windows 95/98/98 Second Edition/NT/Me, you can copy images by inserting the “Memory Stick Duo” into the Memory Stick slot on your computer.
- If the “Memory Stick PRO Duo” is not recognized, see page 117.

## For a computer without a Memory Stick slot:

Make a USB connection and follow Stages to copy images.

- The screen displays shown in this section are the examples for copying images from “Memory Stick Duo”.
- The camera is not compatible with Windows 95/98/98 Second Edition/NT/Me of the Windows operating system.

Use a commercially available Memory Stick Reader/Writer to copy images from a “Memory Stick Duo” to your computer.

To copy images in the internal memory to your computer, copy the images to a “Memory Stick Duo” first, then copy them to your computer.

## Copying images to a computer – Windows Vista/XP

This section describes an example of copying images to the “Documents” (For Windows XP: “My Documents”).

---

### 1 Prepare the camera and a computer.

Perform the same procedure as described in “Preparing the camera and the computer” on page 94.

---

### 2 Connect the camera to your computer with the USB cable.

Perform the same procedure as described in “Connecting the camera to your computer” on page 94.

- If “Picture Motion Browser” is already installed, then [Import Media Files] is started on “Picture Motion Browser” but select [Cancel] to finish.

**3** Click [Open folder to view files] (For Windows XP: [Open folder to view files] → [OK]) as the wizard screen appears automatically on the desktop.



- When the wizard screen does not appear automatically, follow the procedure: → “For Windows 2000”.

**4** Double-click [DCIM].

- When copying movies, double-click on [MP\_ROOT].

**5** Double-click the folder where the image files you want to copy are stored. Then, right-click an image file to display the menu and click [Copy].

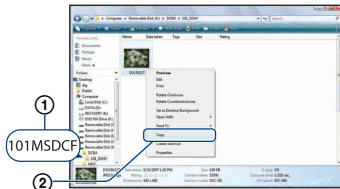

- On the storage destination of the image files, see page 97.

**6** Click the [Documents] (For Windows XP: [My Documents]) folder. Then, right-click on the “Documents” window to display the menu and click [Paste].

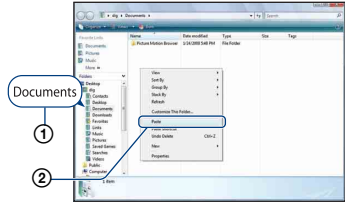

The image files are copied to the [Documents] (For Windows XP: [My Documents]) folder.

- When an image with the same file name exists in the copy destination folder, the overwrite confirmation message appears. When you overwrite an existing image with a new one, the original file data is deleted. To copy an image file to the computer without overwriting, change the file name and then copy the image file. However, note that if you change the file name (page 100), you may not play back that image with the camera.

### For Windows 2000

Double-click [My Computer] → [Removable Disk] after connecting the camera to your computer. Then, perform from step 4.

# Viewing image files stored on a computer with the camera copying to the “Memory Stick Duo”

This section describes the process using a Windows computer as an example. When an image file copied to a computer no longer remains on a “Memory Stick Duo”, you can view that image again on the camera by copying the image file on the camera by copying the image file on the computer to a “Memory Stick Duo”.

- You can copy the image files easily using “Picture Motion Browser”. For details on its operation, see “PMB Guide”.
- Skip step 1 if the file name set with the camera has not been changed.
- You may not be able to play back some images depending on the image size.
- Sony does not guarantee playback of image files on the camera if the files have been processed using a computer or recorded with another camera.
- When there are no folders in a “Memory Stick Duo”, create a folder (page 70) with the camera first, then copy the image files.

- An extension may be displayed depending on the computer settings. The extension for still images is JPG, and the extension for movies is MP4. Do not change the extension.

## 2 Copy the image file to the “Memory Stick Duo” folder in the following order.

- ① Right-click the image file, then click [Copy].
- ② Double-click [Removable Disk] or [SonyMemoryStick] in [Computer] (in Windows XP, [My Computer]).
- ③ Right-click the [□□□MSDCF] (for still image) folder in the [DCIM] folder or [□□□ANV01] (for movie) folder in the [MP\_ROOT] folder and click [Paste].
  - □□□ stands for any number within the range from 100 to 999.

## 1 Right-click the image file, then click [Rename]. Change the file name to “DSC0□□□□”.

Enter a number from 0001 to 9999 for □□□□.

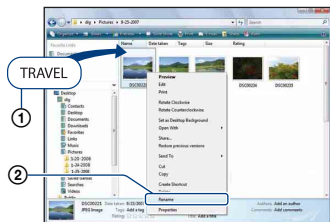

- The movie file names will be saved as “MAH0□□□□.MP4” (1280×720) or “MAQ0□□□□.MP4” (VGA).
- If the overwrite confirmation message appears, enter a different number.

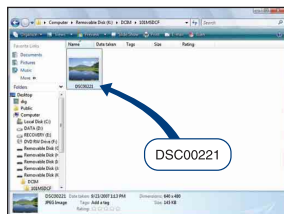

# Using the “Music Transfer” (supplied)

You can change the Music files that are preset at the factory to the desired Music files using “Music Transfer” in the CD-ROM (supplied). You can also delete or add these files whenever you want.

## Adding/Changing Music using “Music Transfer”

The music formats you can transfer with “Music Transfer” are listed below:

- MP3 files stored on the hard disk drive of your computer
- Music on CDs
- Preset-music saved on the camera

- To restore the music preset at the factory to the camera:

① Perform [Format Music] in step 3.

② Execute [Restore defaults] on “Music Transfer”.

All Music files return to the preset-music, and [Music] in the [Slideshow] menu is set to [Off].

- You can reset the Music files to the preset ones using [Initialize] (page 75), however, other settings will also be reset.
- For details on using “Music Transfer”, see the on-line help in “Music Transfer”.

---

**1** Touch [HOME] to display the HOME screen.

---

**2** Touch  (Printing, Other), then touch  Music Tool].

---

**3** Touch [Download Music].

The message “Connect to PC” appears.

---

**4** Make a USB connection between the camera and your computer.

---

**5** Start “Music Transfer”.

---

**6** Follow the instructions on the screen to add/change Music files.

---

# Using your Macintosh computer

You can copy images to your Macintosh computer.

- “Picture Motion Browser” is not compatible with Macintosh computers.

## Recommended computer environment

The following environment is recommended for a computer connected to the camera.

### Recommended environment for copying images

**OS (pre-installed):** Mac OS 9.1/9.2/ Mac OS X (v10.1 to v10.5)

**USB jack:** Provided as standard

### Recommended environment for using “Music Transfer”

**OS (pre-installed):** Mac OS X (v10.3 to v10.5)

**Memory:** 64 MB or more (128 MB or more is recommended)

**Hard Disk:** Disk space required for installation—approximately 250 MB

- Quick Time 7.4 must be pre-installed.

### Notes on connecting the camera to a computer

- Operations are not guaranteed for all the recommended computer environments mentioned above.
- If you connect two or more USB devices to a single computer at the same time, some devices, including the camera, may not operate depending on the types of USB devices you are using.
- Operations are not guaranteed when using a USB hub.
- Connecting the camera using a USB interface that is compatible with Hi-Speed USB (USB 2.0 compliant) allows advanced transfer (high speed transfer) as the camera is compatible with Hi-Speed USB (USB 2.0 compliant).

- There are three modes for a USB connection when connecting a computer, [Auto] (default setting), [Mass Storage] and [PictBridge] modes. This section describes the [Auto] and [Mass Storage] as examples. For details on [PictBridge], see page 76.
- When your computer resumes from the suspend or sleep mode, communication between the camera and your computer may not recover at the same time.

## Copying and viewing images on a computer

### 1 Prepare the camera and a Macintosh computer.

Perform the same procedure as described in “Preparing the camera and the computer” on page 94.

### 2 Connect the camera to your computer with the USB cable.

Perform the same procedure as described in “Connecting the camera to your computer” on page 94.

---

### 3 Copy image files to the Macintosh computer.

- ① Double-click the newly recognized icon → [DCIM] → the folder where the images you want to copy are stored.
- ② Drag and drop the image files to the hard disk icon.  
The image files are copied to the hard disk.
  - For details on the storage location of the images and file names, see page 97.

---

### 4 View images on the computer.

Double-click the hard disk icon → the desired image file in the folder containing the copied files to open that image file.

---

#### To delete the USB connection

Drag and drop the drive icon or the icon of the “Memory Stick Duo” to the “Trash” icon beforehand when you perform the procedures listed below, or the camera is disconnected from the computer.

- Disconnecting the USB cable.
- Removing a “Memory Stick Duo”.
- Inserting a “Memory Stick Duo” into the camera after copying images from the internal memory.
- Turning off the camera.

#### Adding/Changing Music using “Music Transfer”

You can change the Music files that are preset at the factory to the desired Music files. You can also delete or add these files whenever you want.

The music formats you can transfer with “Music Transfer” are listed below:

- MP3 files stored on the hard disk drive of your computer
- Music on CDs
- Preset-music saved on the camera

#### To install “Music Transfer”

- Shut down all other application software before you install “Music Transfer”.
- For installation, you need to log on as Administrator.

- ① Turn on your Macintosh computer, and insert the CD-ROM (supplied) into the CD-ROM drive.
- ② Double-click  (SONYPICUTIL).
- ③ Double-click the [MusicTransfer.pkg] file in [Mac] folder.  
The installation of the software starts.

#### To add/change Music files

See “Adding/Changing Music using “Music Transfer”” on page 101.

#### Technical Support

Additional information on this product and answers to frequently asked questions can be found at the Sony Customer Support Website.  
<http://www.sony.net/>

# Viewing “Cyber-shot Step-up Guide”

When you install “Cyber-shot Handbook”, “Cyber-shot Step-up Guide” is also installed. “Cyber-shot Step-up Guide” further introduces how to use the camera and optional accessories.

## Viewing on Windows

**Double-click  (Step-up Guide) on the desktop.**

To access “Step-up Guide” from the Start menu, click [Start] → [All Programs] (in Windows 2000, [Programs]) → [Sony Picture Utility] → [Step-up Guide].

## Viewing on Macintosh

- 1 Copy the [stepupguide] folder in the [stepupguide] folder to your computer.**
- 2 Select [stepupguide], [language] and then [GB] folder stored in the CD-ROM (supplied), and copy all the files in the [GB] folder to the [img] folder in the [stepupguide] folder that you copied to your computer in step 1. (Overwrite the files in the [img] folder with the files from the [GB] folder.)**
- 3 After copying is complete, double-click “stepupguide.hqx” in the [stepupguide] folder to uncompress it, then double-click the generated file “stepupguide”.**

- If an uncompress tool for HQX file is not installed, install the Stuffit Expander.



# How to print still images

When you print images shot in [16:9] mode, both edges may be cut off, so be sure to check before printing (page 119).

## Printing directly using a PictBridge compliant printer (page 106)



You can print images by connecting the camera directly to a PictBridge compliant printer.

## Printing directly using a “Memory Stick” compliant printer



You can print images with a “Memory Stick” compliant printer. For details, see the operating instructions supplied with the printer.

## Printing using a computer



You can copy images to a computer using the supplied “Picture Motion Browser” software and print the images. You can insert the date on the image and print it.

## Printing at a shop (page 109)

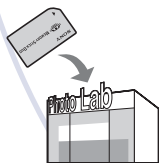

You can take a “Memory Stick Duo” containing images shot with the camera to a photo printing service shop. You can make a **DPOF** (Print order) mark on the images which you want to print out in advance.

# Printing images directly using a PictBridge compliant printer

Even if you do not have a computer, you can print images shot using the camera by connecting the camera directly to a PictBridge compliant printer.



- “PictBridge” is based on the CIPA standard. (CIPA: Camera & Imaging Products Association)
- You cannot print movies.
- If the  indicator flashes on the screen of the camera (error notification), check the connected printer.

## Stage 1: Preparing the camera

Prepare the camera for USB connection to the printer. When [USB Connect] is set to [Auto], the camera will automatically recognize certain printers when connected. Skip Stage 1, if this is the case.

- It is recommended to use a fully charged battery pack to prevent the power from turning off partway through printing.

---

**1** Touch [HOME] to display the HOME screen.

---

**2** Touch  (Settings), and touch [⌵ Main Settings].

---

**3** Touch [USB Connect] in [Main Settings 2].

---

**4** Touch [PictBridge].

The USB mode is set.

---

## Stage 2: Connecting the camera to the printer

**1** Connect the camera to the printer.

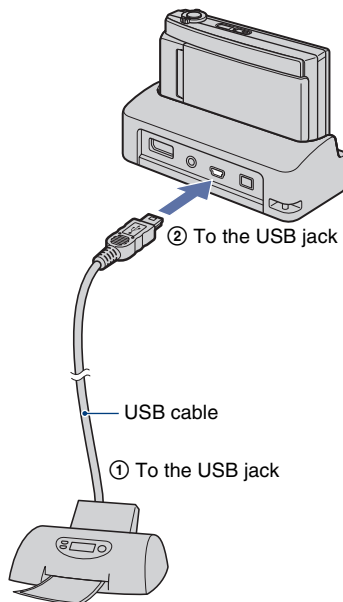

## 2 Turn on the printer, then press (Playback) button.

After the connection is made, the  indicator appears.



The camera is set to playback mode.

## Stage 3: Selecting images you want to print

### 1 Touch [MENU] to display the menu.

### 2 Touch (Print), and touch (Print).



### 3 Touch the desired item.

#### When you select [This Image]

You can print the selected image. Proceed to stage 4.

#### When you select [Multiple Images]

You can print multiple selected images.

- ① Touch the image you want to print. The  mark appears on the selected image.
- ② Touch .
- ③ Touch [OK].

#### When you select [All In This Folder]

Touch [OK], then proceed to stage 4.

## Stage 4: Printing

### 1 Touch the desired setting item to make the print settings.

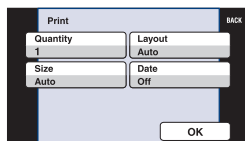

#### [Quantity]

Selects the number of copies of the specified image to be printed.

- The designated number of images may not all fit onto a single sheet depending on the quantity of images.

#### [Layout]

Selects the number of images you want to print side by side on a sheet.

#### [Size]

Selects the size of the printing sheet.

### [Date]

Selects [Day&Time] or [Date] to insert the date and time on images.

- When you choose [Date], the date will be inserted in the order you select (page 81). This function may not be provided depending on the printer.

---

## 2 Touch [OK].

The image is printed.

- Do not disconnect the USB cable while the  (PictBridge Connecting) indicator appears on the screen.

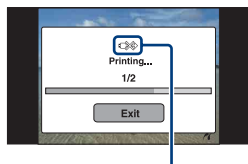

 (PictBridge Connecting) indicator

---

## Stage 5: Completing the printing

Make sure the screen has returned to stage 2, and disconnect the USB cable from the camera.

# Printing at a shop

You can take a “Memory Stick Duo” containing images shot with the camera to a photo printing service shop. As long as the shop supports photo printing services conforming to the DPOF, you can make a **DPOF** (Print order) mark on images in advance so that you do not need to reselect them when you print them out at the shop.

- You cannot print images stored in the internal memory at a print shop directly from the camera. Copy the images to a “Memory Stick Duo”, then take the “Memory Stick Duo” to the print shop.

## What is DPOF?

DPOF (Digital Print Order Format) is a function allowing you to make a **DPOF** (Print order) mark on images of “Memory Stick Duo” that you want to print out later.

- You cannot mark movies.
- You can add a **DPOF** (Print order) mark to a maximum 999 images.

## When taking a “Memory Stick Duo” to a shop

- Consult your photo printing service shop as to what types of “Memory Stick Duo” they handle.
- If a “Memory Stick Duo” is not handled by your photo printing service shop, copy the images you want to print out to another medium such as a CD-R and take it to the shop.
- Be sure to take the Memory Stick Duo Adaptor with it.
- Before you take image data to a shop, always copy (back up) your data to a disk.
- You cannot set the number of prints.
- When you want to superimpose dates on images, consult your photo printing service shop.

## Marking a selected image

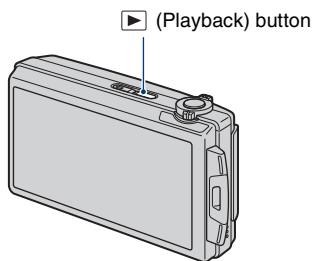

**1** Press  (Playback) button.

**2** Display the image you want to print.

**3** Touch [MENU] to display the menu.

**4** Touch [DPOF] and touch  (This Image).

The **DPOF** (Print order) mark is attached to the image.



## To remove the mark

Select the image from which you want to remove the mark, then repeat steps 3 and 4.

## Selecting and marking the images

**1** Touch [MENU] while displaying images in single-image mode or in index mode.

**2** Touch [DPOF] and touch  (Multiple Images).

**3** Touch an image to mark.

The ✓ mark is attached to the selected image.

Single Image



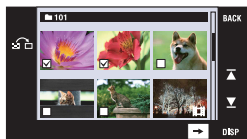

Index Display



**4** Touch .

**5** Touch [OK].

DPOF mark appears on the screen.

- Touching   at the index screen returns to single-image mode.

**To cancel the selection**

Touch [Exit] or [BACK] in step 5.

**To remove the mark**

Touch the images that you want to remove the marks.

## Adding/removing DPOF marks to/from multiple images at once

**1** Touch [MENU] while displaying images in index mode.

**2** Touch [DPOF] and touch [Select All in This Folder] or [Clear All in This Folder].

**3** Touch [OK].

**To cancel the selection**

To cancel, touch [Exit] or [BACK] in step 3.



If you experience trouble with the camera, try the following solutions.

**1 Check the items on pages 112 to 121.**

If a code such as “C/E:□□:□□” appears on the screen, see page 122.

**2 Remove the battery pack, wait for about one minute, re-insert the battery pack, then turn on the power.**

**3 Initialize the settings (page 75).**

**4 Consult your Sony dealer or local authorized Sony service facility.**

Be aware that by sending the camera for repair, you give consent that the contents of the internal memory, Music files may be checked.

Click one of the following items to jump to the page explaining the symptom and cause or the appropriate corrective action.

<b>Battery pack and power</b>	<b>112</b>	<b>Internal memory</b>	<b>119</b>
<b>Shooting still images/movies</b>	<b>113</b>	<b>Printing</b>	<b>119</b>
<b>Viewing images</b>	<b>116</b>	<b>PictBridge compliant printer</b>	<b>120</b>
<b>Deleting</b>	<b>117</b>	<b>Touch panel</b>	<b>121</b>
<b>Computers</b>	<b>117</b>	<b>Others</b>	<b>121</b>
<b>“Memory Stick Duo”</b>	<b>118</b>		

### Battery pack and power

#### Cannot insert the battery pack.

- Insert the battery pack correctly to push the battery eject lever.
- 

#### Cannot turn on the camera.

- Insert the battery pack correctly.
  - The battery pack is discharged. Insert a charged battery pack.
  - The battery pack is dead (page 129). Replace it with a new one.
  - Use a recommended battery pack.
- 

#### The power turns off suddenly.

- If you do not operate the camera for about three minutes while the power is on, the camera turns off automatically to prevent wearing down the battery pack. Turn on the camera again.
  - The battery pack is dead (page 129). Replace it with a new one.
- 

#### The remaining charge indicator is incorrect.

- This phenomenon occurs when you use the camera in an extremely hot or cold location.
  - A discrepancy arose between the remaining charge indicator and the actual remaining battery charge. Fully discharge the battery pack once, then charge it to correct the indication.
  - The battery pack is discharged. Insert a charged battery pack.
  - The battery pack is dead (page 129). Replace it with a new one.
- 

#### Cannot charge the battery pack while it is inside the camera.

- You cannot charge the battery pack using the multi-output stand (supplied) or AC Adaptor (not supplied). Use the battery charger to charge the battery.

## Shooting still images/movies

### Cannot record images.

- Check the free capacity of the internal memory or “Memory Stick Duo”. If it is full, do one of the following:
  - Delete unnecessary images (page 35).
  - Change the “Memory Stick Duo.”
- You cannot record images while charging the flash.
- Set the mode switch.
- The image size is set to [1280×720(Fine)] or [1280×720(Standard)] and “Memory Stick Duo” is inserted when recording movies.  
Do one of the following:
  - Set the image size to [VGA].
  - Insert a “Memory Stick PRO Duo.”

### The start point/end point of a recorded movie differs from the point at which the shutter button was pressed.

- When using this camera, a slight time difference may arise between the time the shutter button is pressed and when recording actually starts/stops. This is not a malfunction.

### The subject is not visible on the screen.

- The camera is set to the playback mode. Press  (Playback) button to switch to the shooting mode (page 31).





### Anti-blur function does not work.

- The anti-blur function does not work when  appears on the display.
- The anti-blur function may not work properly when shooting night scenes.
- Shoot after pressing the shutter button halfway down; do not press it fully down suddenly.

### Recording takes a long time.

- The NR slow shutter function is activated (page 18). This is not a malfunction.











### The image is out of focus.

- The subject is too close. Shoot in  (Macro On) mode. Make sure to position the lens farther away from the subject than the shortest shooting distance (approximately 8 cm (3 1/4 inches) (W) or 80 cm (31 1/2 inches) (T) from the lens). Or set to  (Close focus enabled) mode and shoot about 1 to 20 cm (13/32 to 7 7/8 inches) from the W side distance (pages 28, 30).
-  (Twilight) mode or  (Landscape) mode or  (Fireworks) mode is selected in the Scene Selection when shooting still images.
- The Focus preset function is selected. Select the auto focus mode (page 45).
- Refer to “If the subject is out of focus” on page 46.

### Zoom does not work.

- You cannot use the Optical zoom in  (Close focus enabled) mode.
  - You cannot use the Digital Zoom when shooting movies.
  - You cannot use the Smart zoom depending on the image size (page 79).
- 



### The flash does not work.

- The flash is set to  (Flash forced off) (page 28).
  - You cannot use the flash when:
    - [REC Mode] is set to [Burst] or Exposure Bracket (page 50).
    -  (High Sensitivity) mode or  (Twilight) mode or  (Fireworks) mode is selected in the Scene Selection (page 43).
    - Shooting movies.
  - Set the flash to  (Flash forced on) (page 28) in  (Close focus enabled) mode or when the Scene Selection mode is set to  (Landscape),  (Beach),  (Snow) or  (Hi-Speed Shutter).
- 

### Fuzzy white circular spots appear in images shot using the flash.

- Particles (dust, pollen, etc.) in the air reflected the flash light and appeared in the image. This is not a malfunction (page 14).
- 

### The close-up shoot function (Macro/Close focus enabled) does not work.

-  (Landscape) mode or  (Twilight) mode or  (Fireworks) mode is selected in the Scene Selection (page 43).
- 

### The date and time are not displayed on the LCD screen.

- While shooting, the date and time are not displayed. They are displayed only during playback.
- 

### Cannot insert dates on images.

- This camera does not have a feature for superimposing dates on images (page 119). By using “Picture Motion Browser”, you can print or save images with the date (page 93).
- 

### The F value and shutter speed flash when you press and hold the shutter button halfway down.

- The exposure is incorrect. Correct the exposure (page 49).

---

### **The screen is too dark or too bright.**

- Adjust the brightness of the backlight (page 23).

---

### **The image is too dark.**

- You are shooting a subject with a light source behind the subject. Select the metering mode (page 47) or adjust the exposure (page 49).

---

### **The image is too bright.**

- Adjust the exposure (page 49).

---

### **The image colors are not correct.**

- Set [Color Mode] to [Normal] (page 54).

---

### **Vertical streaks appear when you are shooting a very bright subject.**

- The smear phenomenon is occurring and white, black, red, purple, or other streaks appear on the image. This phenomenon is not a malfunction.

---

### **Noise appears in the image when you view the screen in a dark place.**

- The camera is attempting to increase the visibility of the screen by temporarily brightening the image under conditions of low illumination. There is no effect on the recorded image.

---

### **The eyes of the subject come out red.**

- Set [Red Eye Reduction] to [Auto] or [On] (page 55).
- Shoot the subject at a distance closer than the flash range using the flash.
- Light the room and shoot the subject.
- Retouch the image using [Red Eye Correction] (page 58).

---

### **Dots appear and remain on the screen.**

- This is not a malfunction. These dots are not recorded (page 2).

---

### **Cannot shoot images in succession.**

- The internal memory or “Memory Stick Duo” is full. Delete unnecessary images (page 35).
- The battery level is low. Insert charged battery pack.

### Viewing images

#### Cannot play back images.

- Press  (Playback) button (page 31).
- The folder/file name has been changed on your computer (page 100).
- Sony does not guarantee playback of image files on the camera if the files have been processed using a computer or recorded with another camera.
- The camera is in USB mode. Cancel the USB connection (page 96).
- You cannot play back the movies shot using another camera.

---

#### The images are played back successively.

- [Continuous Play] is set to [On]. Set [Continuous Play] to [Off] (page 74).

---

#### The date and time are not displayed.

- [Display Setup] is set to [Simple] or [Image Only]. Touch [DISP] to set [Display Setup] to [Normal] (page 22).

---

#### The image appears rough right after playback starts.

- This may happen due to image processing. This is not a malfunction.

---

#### Left and right sides of the screen are shown in black.

- [Auto Orientation] is set to [On] (page 80).

---

#### The buttons and icons no longer appear.

- If you touch the top right of the screen during shooting, the buttons and icons will momentarily disappear. The buttons and icons will reappear when you take your finger off the screen.
- [Display Setup] is set to [Image Only]. Touch [DISP] to set [Display Setup] to [Normal] or [Simple]. During playback, display the [DISP] button by touching the center of the LCD screen, then set [Display Setup] to [Normal] or [Simple] (page 22).

---

#### Cannot hear music during slideshow.

- Transfer music files to the camera with “Music Transfer” (page 101).
- Confirm that the volume setting and slideshow setting are correct (pages 33, 61).

---

#### The image does not appear on the TV.

- Check [Video Out] to see if the video output signal of the camera is set to the color system of your TV (page 77).
- Check whether the connection is correct (pages 83, 84).
- If the USB cable is connected to the camera, disconnect it (page 96).

### Deleting

#### Cannot delete an image.

- Cancel the protection (page 65).

### Computers

#### Computer OS compatibility with camera is unknown.

- Check “Recommended computer environment” on page 90 for Windows, and page 102 for Macintosh.

---

#### “Memory Stick PRO Duo” is not recognized by a computer with a “Memory Stick” slot.

- Check that the computer and the Memory Stick Reader/Writer support “Memory Stick PRO Duo”. Users of computers and Memory Stick Readers/Writers made by manufacturers other than Sony should contact those manufacturers.
- If “Memory Stick PRO Duo” is not supported, connect the camera to the computer (pages 94 and 102). The computer recognizes the “Memory Stick PRO Duo”.

---

#### Your computer does not recognize the camera.

- Turn on the camera.
- When the battery level is low, insert the charged battery pack or use the AC adaptor (not supplied) (page 94).
- Set [USB Connect] to [Mass Storage] (page 76).
- Use the USB cable (supplied) (page 94).
- Disconnect the USB cable from both the computer and the multi-output stand, and connect it again firmly.
- Disconnect all equipment other than the camera, the keyboard and the mouse from the USB connectors of your computer.
- Connect the multi-output stand directly to your computer without passing through a USB hub or other device (page 94).

---

#### Cannot copy images.

- Connect the camera and your computer correctly making a USB connection (page 94).
- Follow the designated copy procedure for your OS (pages 95 and 102).
- When you shoot images with a “Memory Stick Duo” formatted by a computer, you may not be able to copy the images to a computer. Shoot using a “Memory Stick Duo” formatted by the camera (page 70).

**After making a USB connection, “Picture Motion Browser” does not start automatically.**

- Make the USB connection after the computer is turned on (page 94).
- 

**Cannot play back images on your computer.**

- If you are using “Picture Motion Browser”, refer to “PMB Guide” (page 93).
  - Consult the computer or software manufacturer.
- 

**You do not know how to use “Picture Motion Browser”.**

- Refer to “PMB Guide” (page 93).
- 

**The image and sound are interrupted by noise when you view a movie on a computer.**

- You are playing back the movie directly from the internal memory or the “Memory Stick Duo”. Copy the movie to the hard disk of your computer, then play back the movie from the hard disk (page 94).
- 

**Cannot print an image.**

- Refer to the operation manual of the printer.
- 

**Images once copied to a computer cannot be viewed on the camera.**

- Copy them to a folder recognized by the camera, such as “101MSDCF” (still images) or “101ANV01” (movies) (page 97).
  - Follow the correct procedures (page 100).
- 

## “Memory Stick Duo”

**Cannot insert a “Memory Stick Duo”.**

- Insert it in the correct direction.
- 

**You have formatted a “Memory Stick Duo” by mistake.**

- All the data on the “Memory Stick Duo” is deleted by formatting. You cannot restore it.

### Internal memory

#### Cannot playback or record images using the internal memory.

- There is a “Memory Stick Duo” inserted in the camera. Remove it.

---

#### Cannot copy the data stored in the internal memory to a “Memory Stick Duo”.

- The “Memory Stick Duo” is full. Copy to a “Memory Stick Duo” with sufficient capacity.

---

#### Cannot copy the data on the “Memory Stick Duo” or the computer to the internal memory.

- This feature is not available.

### Printing

See “PictBridge compliant printer” together with the following items.

---

#### Images are printed with both edges cut off.

- Depending on your printer, all the edges of the image may be cut off. Especially when you print an image shot with the image size set to [16:9], the lateral end of the image may be cut off.
- When printing images using your printer, cancel the trimming or borderless settings. Consult the printer manufacturer as to whether the printer provides these functions or not.
- When having images printed at a digital print shop, ask the shop whether they can print the images without cutting off both edges.

---

#### Cannot print images with the date.

- Using “Picture Motion Browser”, you can print images with date (page 93).
- The camera does not have a feature for superimposing dates on images. However, because the images shot with the camera include information on the recording date, you can print images with the date superimposed if the printer or the software can recognize Exif information. For compatibility with Exif information, consult the manufacturer of the printer or the software.
- If you use a photo printing service, ask them to superimpose the dates on images.

### PictBridge compliant printer

#### A connection cannot be established.

- The camera cannot be connected directly to a printer that is not compliant with the PictBridge standard. Consult the printer manufacturer as to whether the printer is compliant with PictBridge or not.
- Check that the printer is turned on and can be connected to the camera.
- Set [USB Connect] to [PictBridge] (page 76).
- Disconnect and connect the USB cable again. If an error message is indicated on the printer, refer to the operating instructions supplied with the printer.

---

#### Cannot print images.

- Check that the camera and the printer are properly connected using the USB cable.
- Turn on the printer. For further information, refer to the operating instructions supplied with the printer.
- If you select [Exit] during printing, images may not be printed. Disconnect and connect the USB cable again. If you still cannot print your images, disconnect the USB cable, turn the printer off and then on, then connect the USB cable again.
- Movies cannot be printed.
- Images shot using cameras other than this camera, or images modified with a computer may not be printed.

---

#### Printing is canceled.

- Confirm that you have disconnected the USB cable before the  (PictBridge Connecting) mark disappears.

---

#### Cannot insert the date or print images in the index mode.

- The printer does not provide these functions. Consult the printer manufacturer as to whether the printer provides these functions or not.
- The date may not be inserted in the index mode depending on the printer. Consult the printer manufacturer.

---

#### “---- -- --” is printed on the date-inserted part of the image.

- The image does not have the recording data so the date cannot be inserted. Set [Date] to [Off] and print the image again (page 107).

---

#### Cannot select the print size.

- Consult the printer manufacturer as to whether the printer can provide the desired size.

---

### Cannot print the image at the size selected.

- When you use paper of a different size after connecting the printer to the camera, disconnect and then reconnect the USB cable.
- The print setting of the camera differs from that of the printer. Change the setting of either the camera (page 107) or the printer.

---

### Cannot operate the camera after canceling printing.

- Wait for a while as the printer is carrying out the cancellation. It may take some time depending on the printer.

## Touch panel

### Cannot operate the touch panel buttons correctly or fully.

- Perform [Calibration] (page 75).

## Others

### Cannot reset the file-number.

- If you replace a recording medium, you cannot initialize file numbers with the camera. To initialize file numbers, format the “Memory Stick Duo” or the internal memory (pages 70, 73), and then initialize the settings (page 75). However, the data on the “Memory Stick Duo” or the internal memory will be deleted and all settings, including date, will be initialized.

---

### The lens gets fogged.

- Moisture condensation has occurred. Turn off the camera and leave it for about an hour before using it.

---

### The camera becomes warm when you use it for a long time.

- This is not a malfunction.

---

### The Clock Set screen appears when you turn on the camera.

- Set the date and time again (page 81).
- The internal rechargeable backup battery has discharged. Insert a charged battery, and set aside for 24 hours or more with the power left off.

---

### You want to change the date or time.

- Set the date and time again (page 81).

# Warning indicators and messages

## Self-diagnosis display

If a code starting with a letter of the alphabet appears, the self-diagnosis function on the camera is working. The last two digits (indicated by □□) will differ depending on the state of the camera.

If you cannot solve the problem even after trying the following corrective actions a few times, the camera may need repair. Contact your Sony dealer or local authorized Sony service facility.

---

### C:32:□□

- There is trouble with the camera's hardware. Turn the power off and on again.

---

### C:13:□□

- The camera cannot read or write data on the "Memory Stick Duo". Try turning off and on the camera again, or taking out and inserting the "Memory Stick Duo" several times.
- The internal memory has experienced a format error, or an unformatted "Memory Stick Duo" is inserted. Format the internal memory or the "Memory Stick Duo" (pages 70, 73).
- The inserted "Memory Stick Duo" cannot be used with the camera, or the data is damaged. Insert a new "Memory Stick Duo".

---

### E:61:□□

### E:62:□□

### E:91:□□

- A camera malfunction has occurred. Initialize the camera (page 75), then turn the power on again.

## Messages

If the following messages appear, follow the instructions.



- The battery level is low. Charge the battery pack immediately. Depending on the conditions of use or the type of battery pack, the indicator may flash even though there are still 5 to 10 minutes of remaining battery time left.

---

### For use with compatible battery only

- The battery inserted is not an NP-BD1 (supplied)/NP-FD1 (not supplied) battery pack.

---

### System error

- Turn the power off and then on again.

---

### Internal memory error

- Turn the power off and then on again.

---

### Reinsert the Memory Stick

- Insert the "Memory Stick Duo" correctly.
- The inserted "Memory Stick Duo" cannot be used in the camera (page 127).
- The "Memory Stick Duo" is damaged.
- The terminal section of the "Memory Stick Duo" is dirty.

---

### Memory Stick type error

- The inserted "Memory Stick Duo" cannot be used in the camera (page 127).

---

### Cannot access Memory Stick Access denied

- You are using the “Memory Stick Duo” with the access controlled.

---

### Error formatting Memory Stick Error formatting internal memory

- Format the media again (pages 70, 73).

---

### Memory Stick locked

- You are using the “Memory Stick Duo” with the write-protect switch, and the switch is set to the LOCK position. Set the switch to the recording position.

---

### No memory space on internal memory

### No memory space on Memory Stick

- Delete unnecessary images or files (page 35).

---

### Read only memory

- The camera cannot record or delete images on this “Memory Stick Duo”.

---

### No images

- No images that can be played back have been recorded in the internal memory.
- No images that can be played back have been recorded on the “Memory Stick Duo”.
- The selected folder does not contain a file that can be played back in a slideshow.

---

### Folder error

- A folder with the same first three digit number already exists on the “Memory Stick Duo” (for example: 123MSDCF and 123ABCDE). Select another folder, or create a new folder (pages 70, 71).

---

### Cannot create more folders

- The folder with a name beginning with “999” exists on the “Memory Stick Duo”. You cannot create any folders if this is the case.

---

### File error

- An error occurred while the image was playing back. Sony does not guarantee playback of image files on the camera if the files have been processed using a computer or recorded with another camera.

---

### Read only folder

- You have selected a folder that cannot be set as a recording folder on the camera. Select another folder (page 71).

---

### File protected

- Release the protection (page 65).

---

### Image size over limit

- You are playing back an image with size that cannot be played back on the camera.

---

### Invalid operation

- You have selected a function that is not available for movies.
- You have touched the panel when using the digital zoom or close focus mode. While using these modes, you cannot focus by touching the screen.
- You are trying to resize the VGA size image to  (HDTV) with the Multi Resizing function.

---

### No red-eye detected

- You may not be able to retouch the image depending on the image.

---

### (Vibration warning indicator)

- Camera shake may occur due to insufficient light. Use the flash, turn on the anti-blur function, or mount the camera on a tripod to secure the camera.

---

### 1280x720 is not available

- [1280x720(Fine)] and [1280x720(Standard)] size movies can be recorded only using a “Memory Stick PRO Duo”. Insert a “Memory Stick PRO Duo” or set the image size to a size [VGA].

---

### Zoom disabled

- [Digital Zoom] is set to [Off] when you are shooting in  (Close focus enabled) mode. Or, you are trying to use [Smart] in [Digital Zoom] when the image size is set to [10M], [3:2(8M)] or [16:9(7M)] (page 79).

---

### Maximum number of images already selected

- Up to 100 files can be selected when using [Multiple Images].
- You can add **DPOF** marks to up to 999 files.  
Cancel the selection.

---

### Low battery power

- When copying a image recorded in the internal memory to the “Memory Stick Duo”, use a fully charged battery.

---

### Printer busy

#### Paper error

#### No paper

#### Ink error

#### Low ink

#### No ink

- Check the printer.

---

### Printer error

- Check the printer.
- Check if the image you want to print is corrupted.



- The data transmission to the printer may not be completed yet. Do not disconnect the USB cable.

---

### Processing...

- The printer is canceling the current print job. You cannot print until it is finished. This may take time, depending on the printer.

---

### Error Playing Music

- Delete the Music file, or replace it with a normal Music file.
- Execute [Format Music], then download a new Music files.

---

### Error Formatting Music

- Execute [Format Music].

### **Operation cannot be executed in unsupported files**

- Processing and other editing functions of the camera cannot be performed on image files that have been processed using a computer or images that were recorded with another camera.



You can use the camera, the battery charger (supplied), and the AC-LS5K AC Adaptor (not supplied) in any country or region where the power supply is within 100 V to 240 V AC, 50/60 Hz.

- **Do not use an electronic transformer (travel converter), as this may cause a malfunction.**

# On the “Memory Stick Duo”

A “Memory Stick Duo” is a compact, portable IC recording medium. The types of “Memory Stick Duo” that can be used with the camera are listed in the table below. However, proper operation cannot be guaranteed for all “Memory Stick Duo” functions.

“Memory Stick” type	Recording/Playback
Memory Stick Duo (without MagicGate)	○*1
Memory Stick Duo (with MagicGate)	○*2
MagicGate Memory Stick Duo	○*1*2
Memory Stick PRO Duo	○*2*3
Memory Stick PRO-HG Duo	○*2*3*4

- \*1 High-speed data transfer using a parallel interface is not supported.
- \*2 “Memory Stick Duo”, “MagicGate Memory Stick Duo” and “Memory Stick PRO Duo” are equipped with MagicGate functions. MagicGate is copyright protection technology that uses encryption technology. Data recording/playback that requires MagicGate functions cannot be performed with the camera.
- \*3 [1280×720(Fine)] or [1280×720(Standard)] size movies can be recorded.
- \*4 This camera does not support 8-bit parallel data transfer. It performs the same 4-bit parallel data transfer as the Memory Stick PRO Duo.
- This product is compatible with “Memory Stick Micro” (“M2”). “M2” is an abbreviation for “Memory Stick Micro”.
  - A “Memory Stick Duo” formatted with a computer is not guaranteed to operate with the camera.
  - Data read/write speeds differ depending on the combination of the “Memory Stick Duo” and the equipment used.
  - Do not remove the “Memory Stick Duo” while reading or writing data.

- Data may be corrupted in the following cases:
  - When the “Memory Stick Duo” is removed or the camera is turned off during a read or write operation
  - When the “Memory Stick Duo” is used in locations subject to static electricity or electrical noise
- We recommend backing up important data.
- Do not press down hard when you write down on the memo area.
- Do not attach a label on the “Memory Stick Duo” itself nor on a Memory Stick Duo Adaptor.
- When you carry or store the “Memory Stick Duo”, put it in the case supplied with it.
- Do not touch the terminal section of the “Memory Stick Duo” with your hand or a metal object.
- Do not strike, bend or drop the “Memory Stick Duo”.
- Do not disassemble or modify the “Memory Stick Duo”.
- Do not expose the “Memory Stick Duo” to water.
- Do not leave the “Memory Stick Duo” within the reach of small children. They might accidentally swallow it.
- Do not insert anything other than a “Memory Stick Duo” into the “Memory Stick Duo” slot. Doing so will cause a malfunction.
- Do not use or store the “Memory Stick Duo” under the following conditions:
  - High temperature locations such as the hot interior of a car parked in direct sunlight
  - Locations exposed to direct sunlight
  - Humid locations or locations with corrosive substances present

### Notes on using the Memory Stick Duo Adaptor (not supplied)

- To use a “Memory Stick Duo” with a “Memory Stick” compliant device, be sure to insert the “Memory Stick Duo” into a Memory Stick Duo Adaptor. If you insert a “Memory Stick Duo” into a “Memory Stick” compliant device without a Memory Stick Duo Adaptor, you might not be able to remove it from the device.
- When inserting a “Memory Stick Duo” into a Memory Stick Duo Adaptor, make sure the “Memory Stick Duo” is inserted facing in the correct direction, then insert it all the way in. Incorrect insertion may result in a malfunction.
- When using a “Memory Stick Duo” inserted into a Memory Stick Duo Adaptor with a “Memory Stick” compliant device, make sure that the Memory Stick Duo Adaptor is inserted facing the correct direction. Note that improper use may damage the equipment.
- Do not insert a Memory Stick Duo Adaptor into a “Memory Stick” compliant device without a “Memory Stick Duo” attached. Doing so may result in malfunction of the unit.

### Notes on using “Memory Stick PRO Duo” (not supplied)

“Memory Stick PRO Duo” with a capacity up to 16 GB have been confirmed to operate properly with the camera.

### Notes on using “Memory Stick Micro” (not supplied)

- To use a “Memory Stick Micro” with the camera, be sure to insert the “Memory Stick Micro” into an “M2” Adaptor as large as of Duo size. If you insert a “Memory Stick Micro” into the camera without an “M2” Adaptor as large as of Duo size, you might not be able to remove it from the camera.
- Do not leave the “Memory Stick Micro” within the reach of small children. They might accidentally swallow it.

# On the battery pack

## On charging the battery pack

We recommend charging the battery pack in an ambient temperature of between 10°C to 30°C (50°F to 86°F). The battery pack may not be fully charged in temperatures outside this range.

## Effective use of the battery pack

- Battery performance decreases in low temperature surroundings. So in cold places, the operational time of the battery pack is shorter. We recommend the following to ensure longer battery pack use:
  - Put the battery pack in a pocket close to your body to warm it up, and insert it in the camera immediately before you start shooting.
- The battery pack will run out quickly if you use the flash or zoom frequently.
- We recommend having spare battery packs handy for two or three times the expected shooting time, and making trial shots before taking the actual shots.
- Do not expose the battery pack to water. The battery pack is not water-resistant.
- Do not leave the battery pack in extremely hot places, such as in a car or under direct sunlight.

## How to store the battery pack

- Fully discharge the battery pack before storing and store it in a cool, dry place. To maintain the battery pack's function, fully charge the battery pack and then fully discharge it on the camera at least once a year while storing.
- To use the battery pack up, leave the camera in slideshow (page 61) playback mode until the power goes off.
- To prevent staining the terminal, short-circuiting, etc., be sure to use a supplied battery case when carrying and storing.

## On battery life

- The battery life is limited. Battery capacity decreases over time and through repeated use. If decreased usage time between charges becomes significant, it is probably time to replace it with a new one.
- The battery life varies according to how it is stored and the operating conditions and environment in which each battery pack is used.

## Compatible battery pack

- The NP-BD1 (supplied) can be used only in D type compatible Cyber-shot models. It cannot be used in Cyber-shot models compatible with the T type and other battery types.
- If you use the NP-FD1 battery pack (not supplied), the minutes also appear after the battery remaining indicator (  60 Min).

# On the battery charger

## On the battery charger

- Only D-type, T-type, R-type and E-type battery packs (and no others) can be charged in the battery charger (supplied). Batteries other than the specified kind may leak, overheat, or explode if you attempt to charge them, posing a risk of injury from electrocution and burns.
- The batteries that are compatible with this camera are D type batteries. The supplied battery is NP-BD1 (D type).
- Remove the charged battery pack from the battery charger. If you leave the charged battery pack in the charger, battery life may be shortened.
- When the CHARGE lamp flashes, remove the battery pack being charged, and then insert the same battery pack into the battery charger again until it clicks. When the CHARGE lamp flashes again, this may indicate a battery error or that a battery pack other than the specified type has been inserted. Check that the battery pack is the specified type. If the battery pack is the specified type, remove the battery pack, replace it with new one or another one and check if the battery charger operates correctly. If the battery charger operates correctly, a battery error may have occurred.



- A**
- Adjusting EV .....49
  - AE/AF lock indicator.....26, 46
  - AF Illuminator .....78
  - AF lock .....46
  - AF Mode.....79
  - AF range finder frame .....44
  - Aperture .....10
  - Auto Focus.....8, 44
  - Auto Orientation .....80
  - Auto Review .....80
  - AV cable .....83
- B**
- B & W.....54
  - Battery charger.....130
  - Battery pack .....129
  - Beach .....42
  - Beep .....74
  - Blur .....9
  - BRK .....50
  - Burst.....50
- C**
- Calibration .....75
  - Center AF .....44
  - Center-weighted metering ....47
  - Change REC.Folder.....71
  - Clock Settings .....81
  - Close focus enabled .....28
  - Cloudy .....52
  - Color .....11
  - Color Mode.....54
- Computer..... 89
- Copying images
    - ..... 94, 102
    - Macintosh..... 102
    - Recommended environment ..... 90, 102
    - Software ..... 91
    - Viewing image files stored on a computer with the camera ..... 100
    - Windows ..... 89
- Connecting
- Computer ..... 94
  - Printer..... 106
  - TV ..... 83, 84
- Continuous Play ..... 33, 74
- Copy ..... 72
- Copying images to your computer ..... 94, 98
- Create REC.Folder ..... 70
- CTRL FOR HDMI ..... 76
- D**
- Date ..... 81, 108
  - Daylight..... 52
  - Delete ..... 35, 63
    - Format..... 70, 73
  - Deleting images..... 35
  - Digital Zoom ..... 79
  - DISP ..... 22
  - Download Music ..... 101
  - DPOF ..... 66, 109
- E**
- Electronic transformer .....126
  - EV .....49
  - Exposure .....10
  - Exposure Bracket.....50
  - Extension ..... 100
- F**
- Face Detection .....56
  - Fast forward/fast rewind.....31
  - File name .....97
  - File storage destination .....97
  - Fireworks .....42
  - Flash (White Balance) .....53
  - Flash forced off.....28
  - Flash forced on .....28
  - Flash Level .....55
  - Flash mode.....28
  - Fluorescent Light 1, 2, 3.....52
  - Focus.....8, 27, 44
  - Focus preset .....45
  - Folder
    - Changing .....71
    - Creating .....70
    - Selecting.....67
  - Format.....70, 73
  - Format Music.....101
  - Function Guide .....74
- G**
- Grid Line .....78

**H**

HDMI cable .....	84
High Sensitivity .....	41, 42, 43
Hi-Speed Shutter .....	42
Histogram .....	23
HOME screen .....	36

**I**

Identifying parts .....	15
Image file storage destinations and file names .....	97
Image Index .....	32
Image quality .....	12
Image Size .....	12, 27, 30
Incandescent .....	53
Index screen .....	32
Indicator .....	17
Initialize .....	75
Install .....	91
Internal memory .....	24
Internal Memory Tool .....	73
ISO .....	10, 11, 48

**J**

JPG .....	97
-----------	----

**L**

Landscape .....	42
Language Setting .....	82
LCD Screen .....	22

**M**

Macintosh computer .....	102
Recommended environment .....	102
Macro .....	28, 30
Main Settings 1 .....	74
Main Settings 2 .....	76
Manage Memory .....	70
Mass Storage .....	76
“Memory Stick Duo” .....	127
Memory Stick Tool .....	70
Menu	
Items .....	39
Shooting .....	50
Viewing .....	58
Menu screen .....	38
Metering Mode .....	47
Monitor .....	79
Movie mode .....	41
MP4 .....	97
MPEG-4 AVC/H.264 .....	3, 90
Multi AF .....	44
Multi connector .....	15
Multi-output stand .....	16, 83, 94, 106
Multi-pattern metering .....	47
Multi-Purpose Resize .....	60
Music Tool .....	101
Music Transfer .....	101, 103

**N**

Natural .....	54
NR slow shutter .....	18
NTSC .....	77

**O**

Optical zoom .....	27, 30, 79
OS .....	90, 102
Overexposure .....	10

**P**

PAL .....	77
Partial Color .....	59
PC .....	89
PictBridge .....	76, 106
Picture Motion Browser .....	93
Pixel .....	12
Playback zoom .....	32
Precision digital zoom .....	79
Pressing halfway down .....	8
Print .....	66, 105
Print order mark .....	66, 109
Printing at a shop .....	109
Printing directly .....	106
Printing, Other .....	37
Program Auto .....	41
Protect .....	65

**R**

REC Mode .....	41, 50
Red Eye Correction .....	58
Red Eye Reduction .....	55
Retouch .....	58
Rotate .....	67

**S**

- Scene Selection .....42
- Screen
  - Changing the display .....22
  - Indicator.....17
- Select Folder .....67
- Self-diagnosis display .....122
- Self-timer .....27, 30
- Sepia .....54
- Settings .....37, 74
- Setup .....57
- Shooting
  - Movies .....29
  - Still image.....25
- Shooting menu .....50
- Shooting Settings 1 .....78
- Shooting Settings 2 .....80
- Shutter speed.....10
- Single .....79
- Single image screen .....31
- Slideshow .....61
- Slow Synchro.....28
- Smart zoom.....79
- Snow .....42
- Soft Snap.....42
- Software .....91, 93, 101
- Spot AF .....45
- Spot metering.....47
- Spot metering cross hairs.....47
- SteadyShot .....57

**T**

- Touch panel .....21
- Trimming .....58
- Troubleshooting .....111
- TV .....83
- TV TYPE .....77
- Twilight .....42
- Twilight Portrait .....42

**U**

- Underexposure ..... 10
- USB cable ..... 94, 106
- USB Connect..... 76
- USB jack ..... 94
- Using the camera abroad
  - ..... 126

**V**

- VGA ..... 13
- Video Out ..... 77
- Viewing images..... 31
- Viewing menu ..... 58
- Vivid..... 54
- Volume Settings ..... 31, 33, 68

**W**

- Warning indicators and
  - messages ..... 122
- White Balance ..... 52
- Wide Zoom Display ..... 61
- Windows computer ..... 89
  - Recommended
    - environment ..... 90

**Z**

- Zoom ..... 27, 30

## Notes on the License

“C Library”, “Expat” and “zlib” software are provided in the camera. We provide this software based on license agreements with their owners of copyright. Based on requests by the owners of copyright of these software applications, we have an obligation to inform you of the following.

Please read the following sections.

Read “license1.pdf” in the “License” folder on the CD-ROM. You will find licenses (in English) of “C Library”, “Expat” and “zlib” software.

To view the PDF, Adobe Reader is needed.

If it is not installed on your computer, you can download it from the Adobe Systems web page:

<http://www.adobe.com/>

Additional information on this product and answers to frequently asked questions can be found at our Customer Support Website.

<http://www.sony.net/>